

Up to 25 MPa (3630 PSI), 400 L/min (106 U.S.GPM)

■ **Remote Control Relief Valves** Page 3

This valve is used as a remote control valve for pilot operated type pressure control valves.

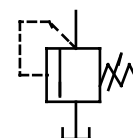
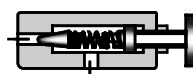

■ **Direct Type Relief Valves** Page 6

This valve is used in a hydraulic circuit to prevent damage due to over pressure and to adjust the maximum circuit pressure of small capacity.

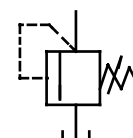

■ **Pilot Operated Relief Valves** Page 9

These valves protect the hydraulic system from excessive pressure, and can be used to maintain constant pressure in a hydraulic system. Remote control and unloading are permitted by using vent circuits.

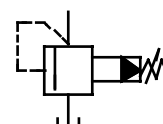
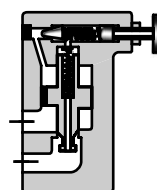

■ **Low Noise Type Pilot Operated Relief Valves** Page 16

Pilot operated relief valves here have been particularly developed as low-noise types. Able to protect pumps and control valves against excessive pressures, they are used to control the pressure in the hydraulic system to a constant level. Remote control and unloading are permitted by using vent circuits.

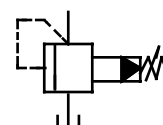
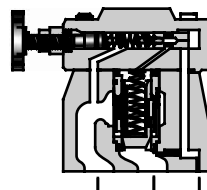

■ **Solenoid Controlled Relief Valves** Page 20

These valves are a combination of a pilot operated relief valve and a solenoid operated directional valve. Piping between the two is eliminated as the solenoid valve is directly mounted on the relief valve and connected with the relief valve vent. Pump pressure may be unloaded remotely by an electrical signal to the solenoid, or by connecting pilot relief valves to the solenoid valve ports.

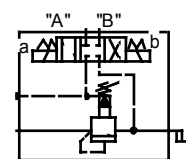
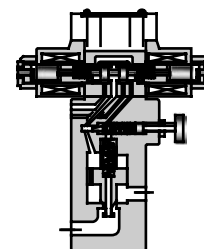

■ **Low Noise Type Solenoid Controlled Relief Valves** Page 31

The low-noise solenoid controlled relief valve is a combination of a low-noise type pilot operated relief valve and a solenoid operated directional valve. It is used for no-load pump operation by using electric signals or, together with a remote control relief valve, for two or three pressure control of the hydraulic system.

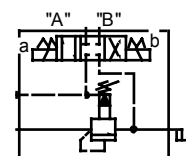
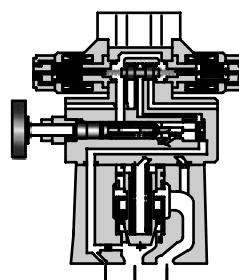

 **CAUTION**

When making replacement of seals or solenoid assemblies, please do it carefully after reading through the relevant instructions in the Operator's Manual.

■ **Instructions**

- To adjust the pressure, loosen the lock nut and turn the handle slowly clockwise for higher pressures or anti-clockwise for lower pressures. After adjustments, do not forget to tighten the lock nut.
- Piping of the tank line should not be connected to any tank line of the other valves, but connected directly to the tank.

■ **Hydraulic Fluids**

● **Fluid Types**

Any type of hydraulic fluids listed in the table below can be used.

Petroleum base oils	Use fluids equivalent to ISO VG 32 or VG 46.
Synthetic fluids	Use phosphate ester or polyol ester fluid. When phosphate ester fluid is used, prefix "F-" to the model number because the special seals (fluororubber) are required to be used.
Water containing fluids	Use water-glycol fluid.

Note: For use with hydraulic fluids other than those listed above, please consult your Yuken representatives in advance.

● **Recommended Viscosity and Oil Temperatures**

Viscosity ranging between 15 - 400 mm²/s (77 - 1800 SSU).

Oil temperatures between -15/+70°C (5 - 158°F).

Use hydraulic fluids which satisfy the recommended viscosity and oil temperatures given above.

● **Control of Contamination**

Due caution must be paid to maintaining control over contamination of the hydraulic fluids which may otherwise lead to breakdowns and shorten the life of the valves. Please maintain the degree of contamination within NAS 1638-Grade 12. Use 25 μm or finer line filter.



■ Specifications



Model Numbers		Max. Operating Pres. MPa (PSI)	Approx. Mass kg (lbs.)	
Threaded Connection	Sub-plate Mounting		DT type	DG type
DT-01-22*	DG-01-22*	25 (3630)	1.6 (3.5)	1.4 (3.1)

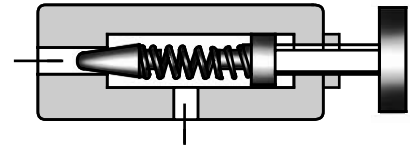

■ Model Number Designation

F-	D	T	-01	-22	*
Special Seals	Series Number	Type of Mounting	Valve Size	Design Number	Design Standards
F: Special Seals for Phosphate Ester Type Fluids (Omit if not required)	D: Remote Control Relief Valves	T: Threaded Connection	01	22	None: Japanese Std. "JIS" 80: European Design Std. 90: N. American Design Std.
		G: Sub-plate Mounting		22	None: Japanese Std. "JIS" and European Design Std. 90: N. American Design Std.

■ Instructions

- Pressure is limited by collars fitted. If a working pressure cannot be attained, remove some collars. One collar is equivalent to 10 MPa (1450 PSI).
- If the internal volume of the vent line is too large, chattering is likely to occur.

Graphic Symbol

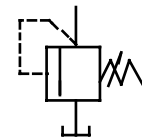

■ Attachment

● Mounting bolts

Valve Model Numbers	Socket Head Cap Screw		Qty.
	Japanese Std. "JIS" and European Design Std.	N. American Design Std.	
DG-01	M5 × 45 Lg.	No.10-24UNC × 1-3/4 Lg.	4

■ Sub-plate

Valve Model Numbers	Japanese Standard "JIS"		European Design Standard		N. American Design Standard		Approx. Mass kg (lbs.)
	Sub-plate Model Numbers	Thread Size	Sub-plate Model Numbers	Thread Size	Sub-plate Model Numbers	Thread Size	
DG-01	DGM-02-20	Rc 1/4	DGM-02-2080	1/4 BSP.F	DGM-02-2090	1/4 NPT	0.7 (1.5)

- Sub-plates are available. Specify the sub-plate model number from the table above. When sub-plates are not used, the mounting surface should have a good machined finish.

DT-01-22/2280/2290

DIMENSIONS IN
MILLIMETRES (INCHES)

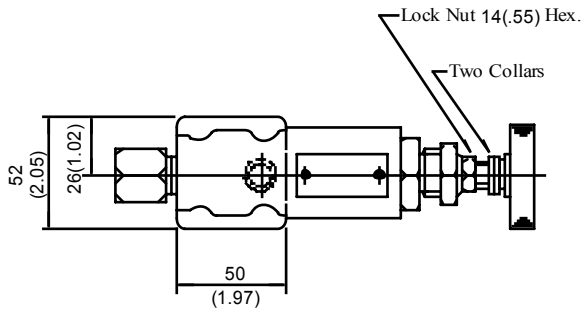

Model Numbers	"A" Thd.
DT-01-22	Rc 1/4
DT-01-2280	1/4 BSP.F
DT-01-2290	1/4 NPT

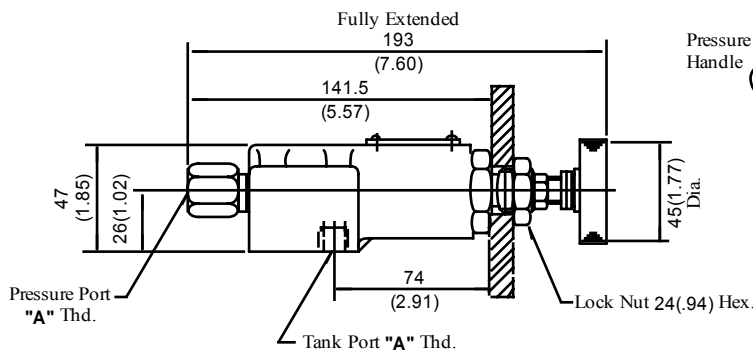

Dimensions of
The Panel Mounting Hole

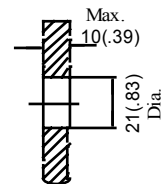

DG-01-22/2290

Sub-plate: DGM-02-20/2080/2090

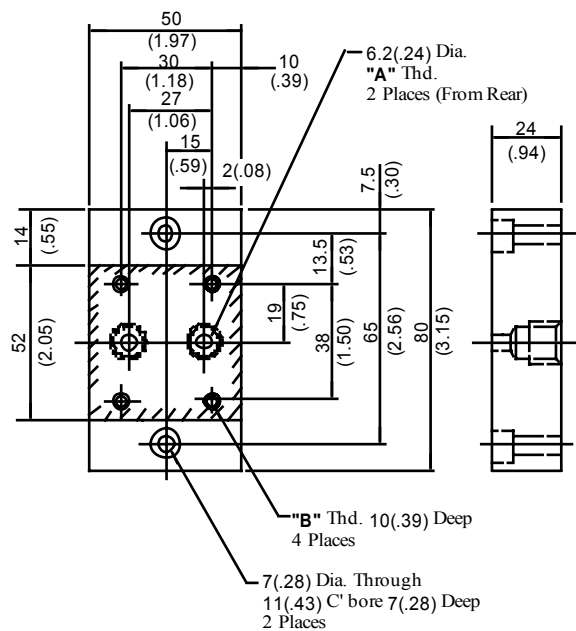
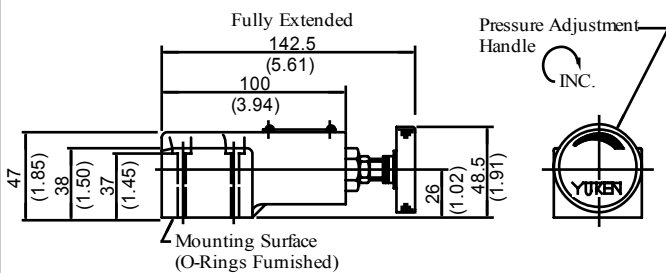
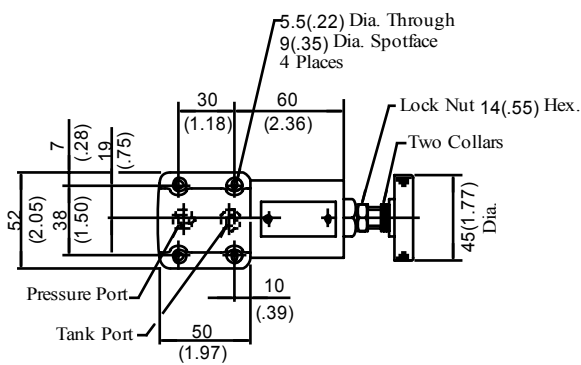

Model Numbers	"A" Thd.	"B" Thd.
DGM-02-20	Rc 1/4	M5
DGM-02-2080	1/4 BSP.F	
DGM-02-2090	1/4 NPT	No. 10-24 UNC

⚠ CAUTION

When making replacement of seals, please do it carefully after reading through the relevant instructions in the Operator's Manual.

DT-01-22/2280/2290

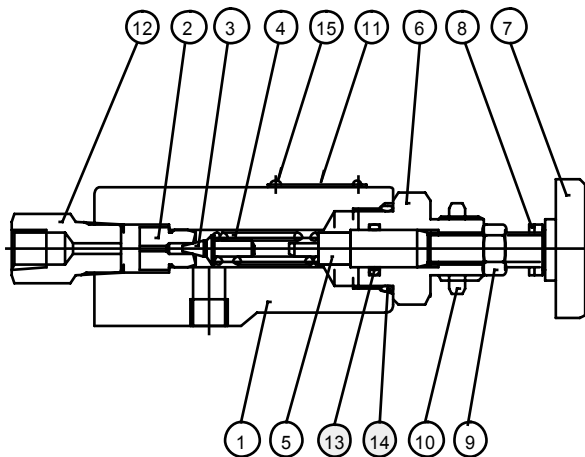

● List of Seals

Item	Name of Parts	Parts Numbers	Qty.
13	O-Ring	SO-NA-P12	1
14	O-Ring	SO-NB-P22.4	1

Note: When ordering the seals, please specify the seal kit number from the table below.

● List of Seal Kits

Model Numbers	Seal Kit Numbers
DT-01	KS-DT-01-22
DG-01	KS-DG-01-22

DG-01-22/2290

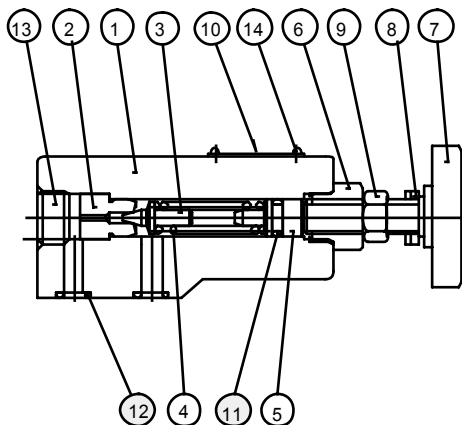

● List of Seals

Item	Name of Parts	Parts Numbers	Qty.
11	O-Ring	SO-NA-P9	1
12	O-Ring	SO-NB-P9	2

Note: When ordering the seals, please specify the seal kit number from the table below.

C



■ Specifications

Model Numbers		Max. Operating Pressure MPa (PSI)	Pres. Adj. Range MPa (PSI)	Max. Flow L/min (U.S.GPM)	Approx. Mass kg (lbs.)	
Threaded Connections	Sub-plate Mounting				DT type	DG type
DT-02-* -22*	DG-02-* -22*	21 (3050)	Note)	16 (4.22)	1.5 (3.3)	1.5 (3.3)

Note: Refer to the Model Number Designation.

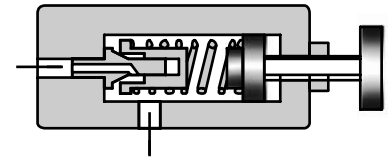

■ Model Number Designation

F-	D	T	-02	-B	-22	*
Special Seals	Series Number	Type of Mounting	Valve Size	Pres. Adj. Range MPa (PSI)	Design Number	Design Standards
F: Special Seals for Phosphate Ester Type Fluids (Omit if not required)	D: Direct Type Relief Valves	T: Threaded Connection G: Sub-plate Mounting	02	B: ★-7 (★-1020) C: 3.5-14 (510-2030) H: 7-21 (1020-3050)	22 22	None: Japanese Std. "JIS" 80: European Design Std. 90: N. American Design Std. None: Japanese Std. "JIS" and European Design Std. 90: N. American Design Std.

★ Refer to the Minimum Adjustment Pressure Characteristics.

Graphic Symbol

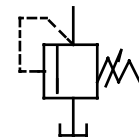

■ Attachment

● Mounting bolts

Valve Model Numbers	Socket Head Cap Screw		Qty.
	Japanese Std. "JIS" and European Design Std.	N. American Design Std.	
DG-02	M5 × 45 Lg.	No.10-24UNC × 1-3/4 Lg.	4

■ Sub-plate

Valve Model Numbers	Japanese Standard "JIS"		European Design Standard		N. American Design Standard		Approx. Mass kg (lbs.)
	Sub-plate Model Numbers	Thread Size	Sub-plate Model Numbers	Thread Size	Sub-plate Model Numbers	Thread Size	
DG-02	DGM-02-20	Rc 1/4	DGM-02-2080	1/4 BSP.F	DGM-02-2090	1/4 NPT	0.7 (1.5)

- Sub-plates are available. Specify the sub-plate model number from the table above. When sub-plates are not used, the mounting surface should have a good machined finish.
- The sub-plates are those for remote control relief valves. For dimensions, see page 4.

■ Min. Adjustment Pressure

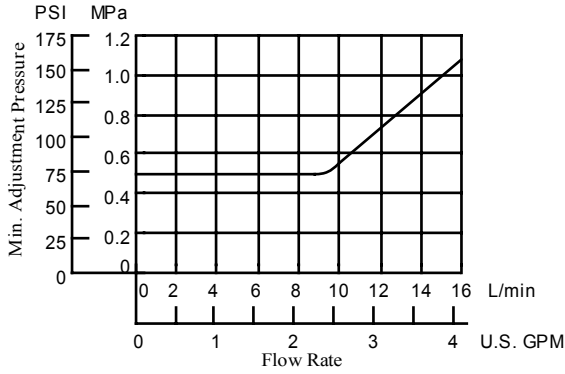

■ Nominal Override Characteristics

Hydraulic fluid: Viscosity : 35 mm²/s (164 SSU)
Specific Gravity : 0.850

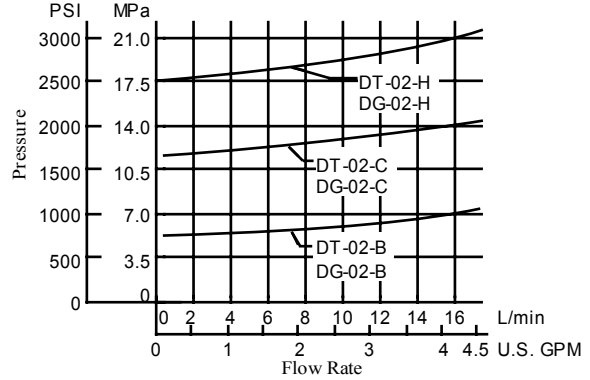

DT-02-*-22/2280/2290

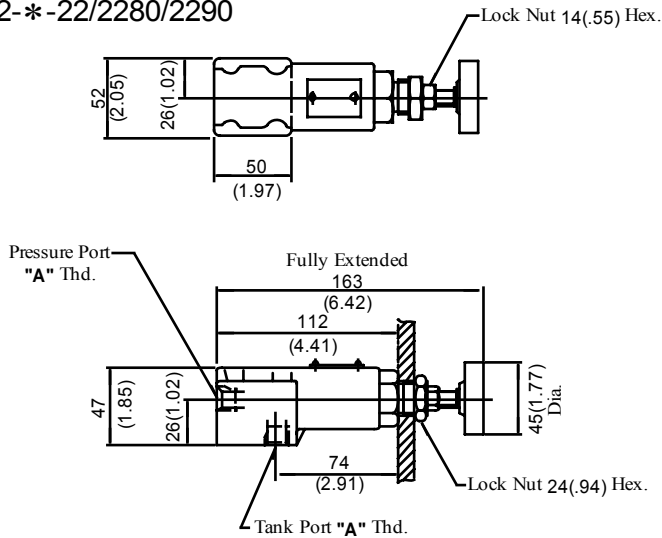

Model Numbers	"A" Thd.
DT-02-*-22	Rc 1/4
DT-02-*-	1/4 BSP.F
2280	1/4 NPT

Dimensions of
The Panel Mounting Hole

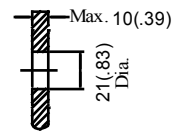

DG-02-*-22/2290

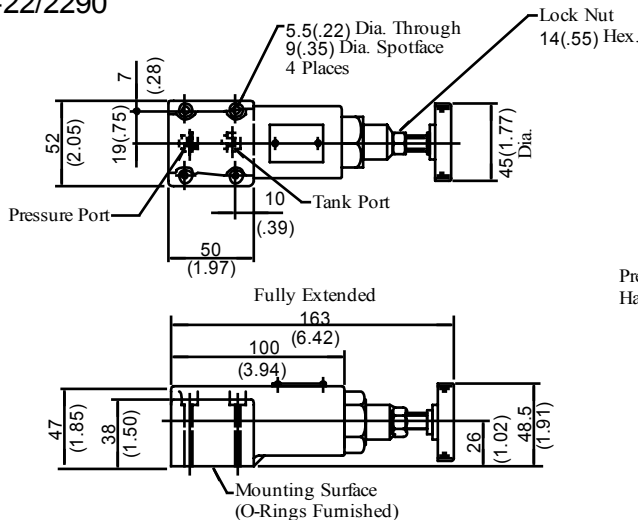

**DIMENSIONS IN
MILLIMETRES (INCHES)**

Note: For dimensions of the valve mounting surface, see the dimensional drawing (P.4) of the sub-plate used together.



DT-02-* -22/2280/2290

DG-02-* -22/2290



CAUTION

When making replacement of seals, please do it carefully after reading through the relevant instructions in the Operator's Manual.

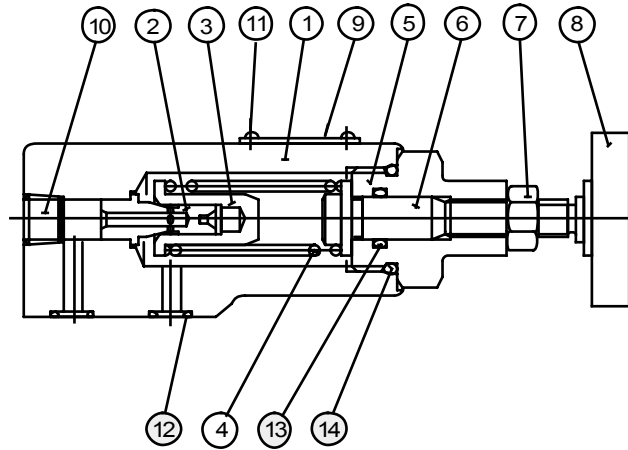

● List of Seals

Item	Name of Parts	Part Numbers	Qty.	Remarks
12	O-Ring	SO-NB-P9	2	Use only for DG-02
13	O-Ring	SO-NA-P12	1	—
14	O-Ring	SO-NB-P22.4	1	—

Note: When ordering the seals, please specify the seal kit number from the table below.

● List of Seal Kits

Model Numbers	Seal Kit Numbers
DT-02	KS-DT-01-22
DG-02	KS-DG-02-22

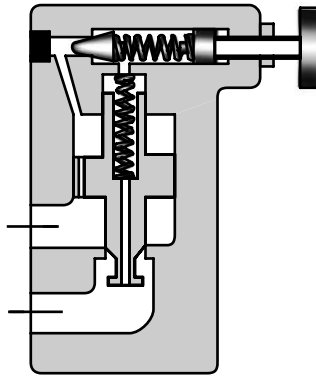

Graphic Symbols

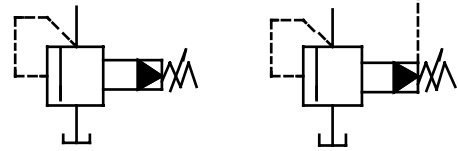

Vent Connection

Specifications

Model Numbers		Max. Operating Pressure MPa (PSI)	Pres. Adj. Range MPa (PSI)	Max. Flow L/min (U.S.GPM)	Approx. Mass kg (lbs.)	
Threaded Connection	Sub-plate Mounting				BT type	BG type
BT-03-*-32*	BG-03-*-32*	25 (3630)	Note ★-25 (★-3630)	100 (26.4)	5.0 (11.0)	4.7 (10.4)
BT-06-*-32*	BG-06-*-32*			200 (52.8)	5.0 (11.0)	5.6 (12.3)
BT-10-*-32*	BG-10-*-32*			400 (106)	8.5 (18.7)	8.7 (19.2)

Note: Refer to the Minimum adjustment Pressure characteristics on page 14.

Yuken can offer flanged connection valves described below.
For details, contact us.

Model Numbers	Max Operating Pres. MPa (PSI)	Max Flow L/min (U.S.GPM)
BF-10-*-32*	25 (3630)	400 (106)
BF-16-*-32*		800 (211)
BF-24-*-20*	21 (3050)	1200 (317)

Model Number Designation

F-	B	T	-03	-V	-32	*
Special Seals	Series Number	Type of Mounting	Valve Size	High Venting [★] Pres. Feature	Design Number	Design Standards
F: Special Seals for Phosphate Ester Type Fluids (Omit if not required)	B: Pilot Operated Relief Valves	T: Threaded Connection	03	V: For High Venting Pressure Feature (Omit if not required)	32	None: Japanese Std. "JIS" 80: European Design Std. 90: N. American Design Std.
			06		32	
			10		32	
		G: Sub-plate Mounting	03		32	None: Japanese Std. "JIS" and European Design Std. 90: N. American Design Std.
			06		32	
			10		32	

★ Use high venting pressure type to reduce the response time from unload to onload.



■ Attachment

● Mounting Bolts

Valve Model Numbers	Socket Head Cap Screw	
	Japanese Std. "JIS" and European Design Std.	N. American Design Std.
BG-03	M12 × 70 Lg. (2 pcs.), M12 × 95 Lg. (2 pcs.)	1/2-13UNC × 2-3/4 Lg. (2 pcs.), 1/2-13UNC × 3-3/4 Lg. (2 pcs.)
BG-06	M16 × 60 Lg. (2 pcs.), M16 × 80 Lg. (2 pcs.)	5/8-11UNC × 2-1/4 Lg. (2 pcs.), 5/8-11UNC × 3-1/4 Lg. (2 pcs.)
BG-10	M20 × 70 Lg. (2 pcs.), M20 × 90 Lg. (2 pcs.)	3/4-10UNC × 2-3/4 Lg. (2 pcs.), 3/4-10UNC × 3-1/2 Lg. (2 pcs.)

■ Sub-plate

Valve Model Numbers	Japanese Standard "JIS"		European Design Standard		N. American Design Standard		Approx. Mass kg (lbs.)
	Sub-plate Model Numbers	Thread Size	Sub-plate Model Numbers	Thread Size	Sub-plate Model Numbers	Thread Size	
BG-03	BGM-03-20	Rc 3/8	BGM-03-3080	3/8 BSP.F	BGM-03-2090	3/8 NPT	2.4(5.3)
	BGM-03X-20	Rc 1/2	BGM-03X-3080	1/2 BSP.F	BGM-03X-2090	1/2 NPT	3.1(6.8)
BG-06	BGM-06-20	Rc 3/4	BGM-06-3080	3/4 BSP.F	BGM-06-2090	3/4 NPT	4.7(10.4)
	BGM-06X-20	Rc 1	BGM-06X-3080	1 BSP.F	BGM-06X-2090	1 NPT	5.7(12.6)
BG-10	BGM-10-20	Rc 1-1/4	BGM-10-3080	1-1/4 BSP.F	BGM-10-2090	1-1/4 NPT	8.4(18.5)
	BGM-10X-20	Rc 1-1/2	BGM-10X-3080	1-1/2 BSP.F	BGM-10X-2090	1-1/2 NPT	10.3(22.7)

◆ Sub-plates are available. Specify the sub-plate model number from the table above. When sub-plates are not used, the mounting surface should have a good machined finish.

■ Instructions

- If a remote control relief valve is used in the vent circuit, see page 3. In addition, if the internal volume of the vent line is too large, chattering is likely to occur. Thus, as far as possible reduce the inside Dia. and the length of the pipe.
- Pressure is limited by collars fitted. If a working pressure cannot be attained, remove some collars. One collar is equivalent to 10 MPa (1450 PSI).
- With a small flow, the setting pressure may be unstable. Use models numbered 03 and 06 with a flow rate above 8 L/min (2.1 U.S. GPM) and model 10 with 15 L/min (4.0 U.S. GPM).
- There are two threaded connection pressure ports. They can be connected each other in-line; one as inlet and the other as an outlet or the valve can be used by plugging one of the pressure ports.

BT-03-* -32/3280/3290

BT-06-* -32/3280/3290

BT-10-* -32/3280/3290

DIMENSIONS IN
MILLIMETRES (INCHES)

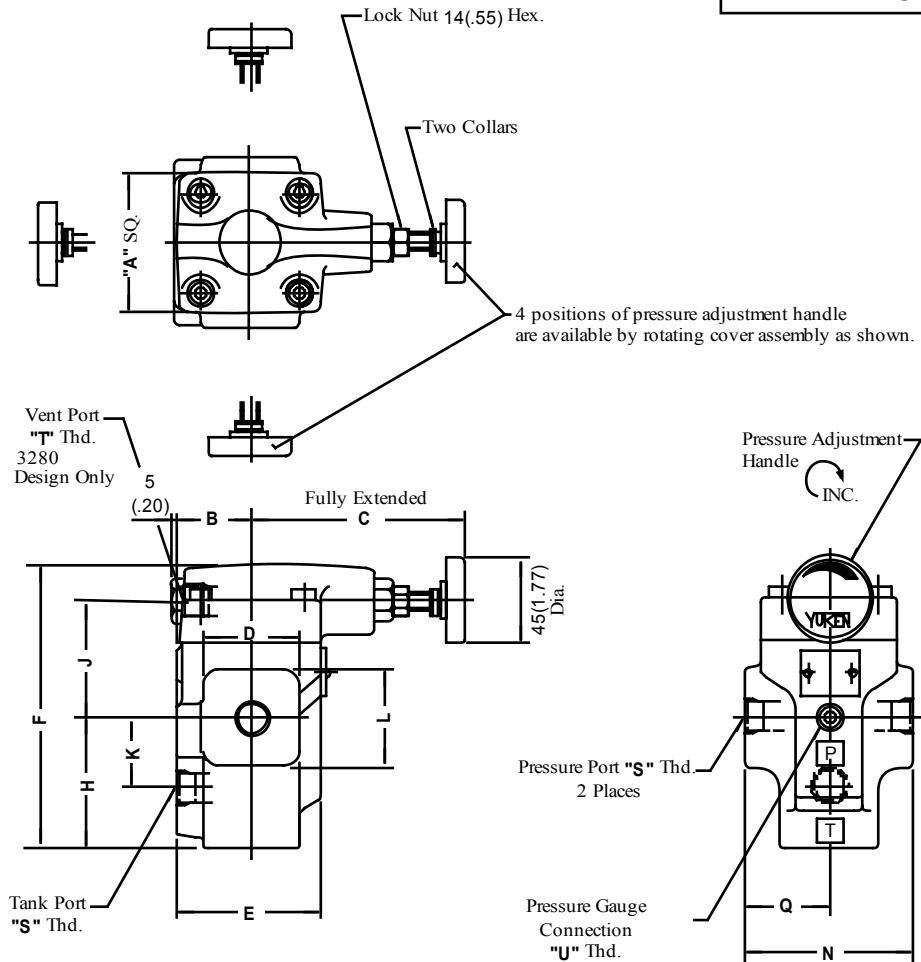

Model Numbers	Dimensions mm (Inches)											
	A	B	C	D	E	F	H	J	K	L	N	Q
BT-03-* -32/3280/3290	75 (2.95)	40 (1.57)	105 (4.13)	52 (2.05)	78 (3.07)	150.5 (5.93)	68.5 (2.70)	62 (2.44)	36 (1.42)	52 (2.05)	90 (3.54)	45 (1.77)
BT-06-* -32/3280/3290												
BT-10-* -32/3280/3290	85 (3.35)	50 (1.97)	101 (3.98)	80 (3.15)	96 (3.78)	183 (7.20)	89 (3.50)	74 (2.91)	49 (1.93)	80 (3.15)	120 (4.72)	60 (2.36)

Model Numbers	Thread Size		
	"S" Thd.	"T" Thd.	"U" Thd.
BT-03-* -32	Rc 3/8	Rc 3/8	Rc 1/4
BT-03-* -3280	3/8 BSP.F	3/8 BSP.F	1/4 BSP.Tr
BT-03-* -3290	3/8 NPT	3/8 NPT	1/4 NPT
BT-06-* -32	Rc 3/4	Rc 3/8	Rc 1/4
BT-06-* -3280	3/4 BSP.F	3/8 BSP.F	1/4 BSP.Tr
BT-06-* -3290	3/4 NPT	3/8 NPT	1/4 NPT
BT-10-* -32	Rc 1-1/4	Rc 3/8	Rc 1/4
BT-10-* -3280	1-1/4 BSP.F	3/8 BSP.F	1/4 BSP.Tr
BT-10-* -3290	1-1/4 NPT	3/8 NPT	1/4 NPT

BG-03-* -32/3290

BG-06-* -32/3290

BG-10-* -32/3290

MENSIONS IN
MILLIMETRES (INCHES)

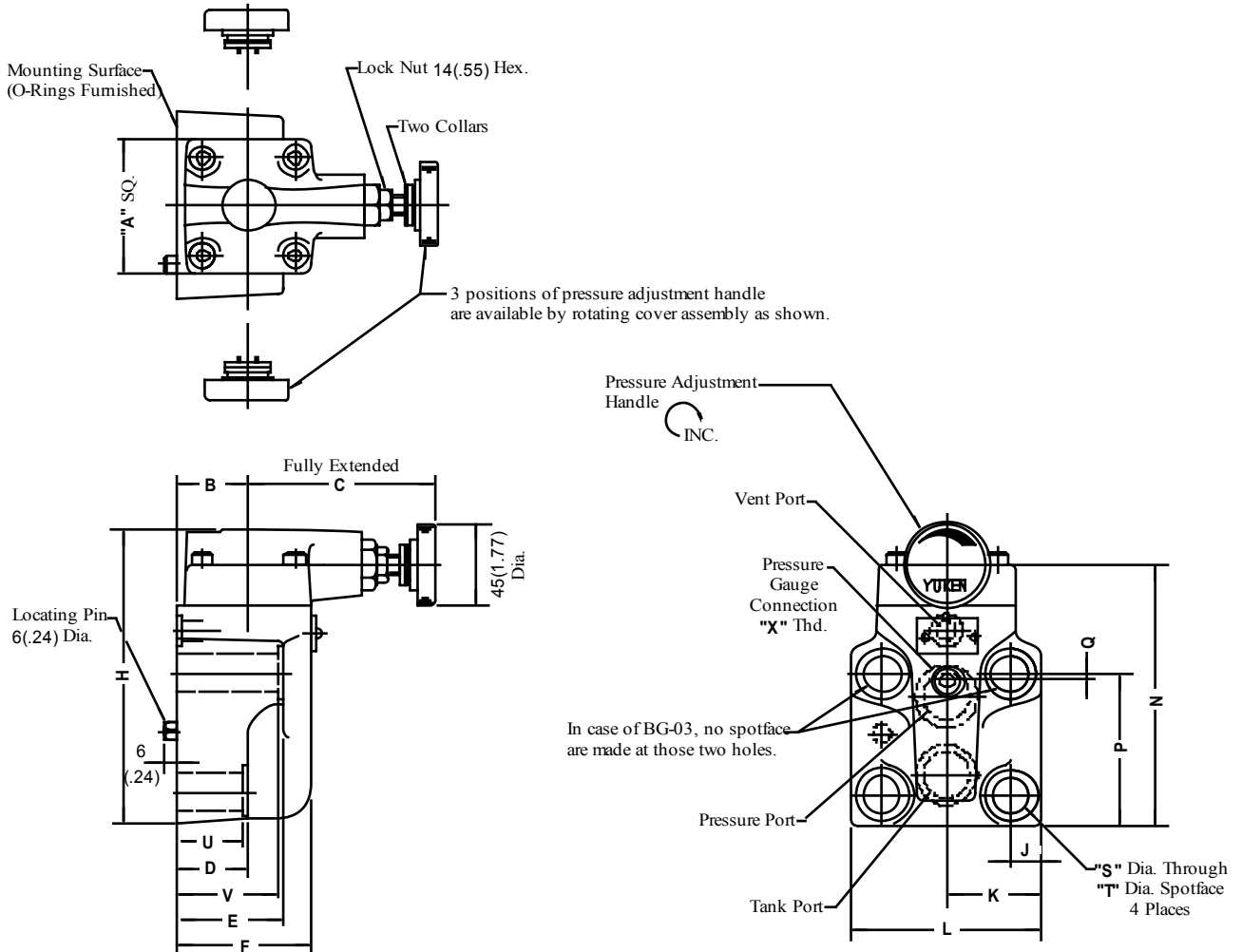

Model Numbers	Dimensions mm (Inches)																
	A	B	C	D	E	F	H	J	K	L	N	P	Q	S	T	U	V
BG-03-* -32/3290	75 (2.95)	40 (1.57)	105 (4.13)	57 (2.24)	78 (3.07)	78 (3.07)	137 (5.39)	14.1 (.56)	41 (1.61)	82 (3.23)	117 (4.61)	77 (3.03)	22 (.87)	13.5 (.53)	21 (.83)	55 (2.17)	—
BG-06-* -32/3290	75 (2.95)	40 (1.57)	105 (4.13)	40 (1.57)	60 (2.36)	78 (3.07)	161 (6.34)	17 (.67)	52 (2.05)	104 (4.09)	141 (5.55)	83.5 (3.29)	4.5 (.18)	17.5 (.69)	26 (1.02)	38 (1.50)	58 (2.28)
BG-10-* -32/3290	85 (3.35)	45 (1.77)	101 (3.98)	47 (1.85)	67 (2.64)	84 (3.31)	195 (7.68)	20.7 (.81)	62 (2.44)	124 (4.88)	175 (6.89)	110 (4.33)	6 (.24)	21.5 (.85)	32 (1.26)	45 (1.77)	65 (2.56)

Model Numbers	Thread Size	Mounting Surface
	"X" Thd	
BG-03-* -32	Rc 1/4 = 1/4 BSP.Tr	ISO 6264-AR-06-2-A
BG-03-* -3290	1/4 NPT	
BG-06-* -32	Rc 1/4 = 1/4 BSP.Tr	ISO 6264-AS-08-2-A
BG-06-* -3290	1/4 NPT	
BG-10-* -32	Rc 1/4 = 1/4 BSP.Tr	ISO 6264-AT-10-2-A
BG-10-* -3290	1/4 NPT	

BGM-03,03X-20 / 3080 / 2090

BGM-06,06X-20 / 3080 / 2090

BGM-10,10X-20 / 3080 / 2090

DIMENSIONS IN MILLIMETRES (INCHES)

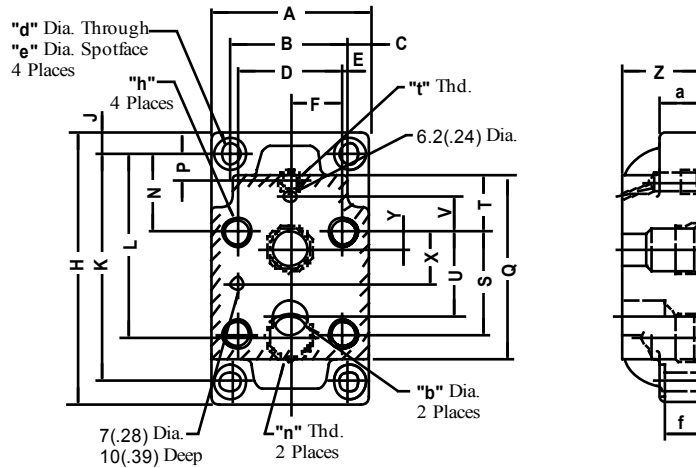

Model Numbers	Dimensions mm (Inches)													
	A	B	C	D	E	F	H	J	K	L	N	P	Q	S
BGM-03	86 (3.39)	60 (2.36)	13 (.51)	53.8 (2.12)	3.1 (.12)	26.9 (1.06)	149 (5.87)	13 (.51)	123 (4.84)	86 (3.39)	32 (1.26)	26 (1.02)	97 (3.82)	53.8 (2.12)
BGM-03X										95 (3.74)	21 (.83)			
BGM-06	108 (4.25)	78 (3.07)	15 (.59)	70 (2.76)	4 (.16)	35 (1.38)	180 (7.09)	15 (.59)	150 (5.91)	106.5 (4.19)	51 (2.01)	27.2 (1.07)	121 (4.76)	66.7 (2.63)
BGM-06X										119 (4.69)	18 (.71)			
BGM-10	126 (4.96)	94 (3.70)	16 (.63)	82.6 (3.25)	5.7 (.22)	41.3 (1.63)	227 (8.94)	16 (.63)	195 (7.68)	138.2 (5.44)	62 (2.44)	30.2 (1.19)	154 (6.06)	88.9 (3.50)
BGM-10X										158 (6.22)	17 (.67)			

Model Numbers	Dimensions mm (Inches)										
	T	U	V	X	Y	Z	a	b	d	e	f
BGM-03	19 (.75)	47.4 (1.87)	0 (0)	22 (.87)	22 (.87)	32 (1.26)	20 (.79)	14.5 (.57)	11 (.43)	17.5 (.69)	19 (.75)
BGM-03X						40 (1.57)					
BGM-06	37 (1.46)	55.5 (2.19)	23.8 (.94)	33.4 (1.31)	11 (.43)	40 (1.57)	25 (.98)	23 (.91)	13.5 (.53)	21 (.83)	24 (.94)
BGM-06X						50 (1.97)					
BGM-10	42 (1.65)	76.2 (3.00)	31.8 (1.25)	44.5 (1.75)	12.7 (.50)	50 (1.97)	32 (1.26)	28 (1.10)	17.5 (.69)	26 (1.02)	31 (1.22)
BGM-10X						63 (2.48)					

Model Numbers	Japanese Standard "JIS" Design "20"			European Design Standard Design "3080"			N. American Design Standard Design "2090"		
	"h"	"n" Thd.	"t" Thd.	"h"	"n" Thd.	"t" Thd.	"h"	"n" Thd.	"t" Thd.
BGM-03	M12 Thd. 20(.79) Deep	Rc 3/8	Rc 1/4	M12 Thd. 20(.79) Deep	3/8 BSP.F	1/4 BSP.F	1/2-13UNC Thd. 22(.87) Deep	3/8 NPT	1/4 NPT
BGM-03X		Rc 1/2			1/2 BSP.F			1/2 NPT	
BGM-06	M16 Thd. 25(.98) Deep	Rc 3/4		M16 Thd. 25(.98) Deep	3/4 BSP.F		5/8-11UNC Thd. 27(1.06) Deep	3/4 NPT	
BGM-06X		Rc 1			1 BSP.F			1 NPT	
BGM-10	M20 Thd. 28(1.10) Deep	Rc 1-1/4	M20 Thd. 28(1.10) Deep	1-1/4 BSP.F	3/4-10UNC Thd. 28(1.10) Deep	1-1/4 NPT			
BGM-10X		Rc 1-1/2		1-1/2 BSP.F		1-1/2 NPT			

Nominal Override Characteristics

Hydraulic fluid: Viscosity : 35 mm²/s (164 SSU)
Specific Gravity : 0.850

BT-03, BG-03

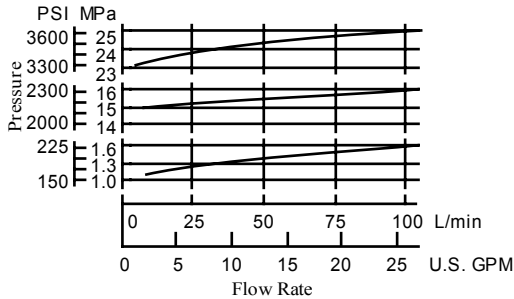

BT-06, BG-06

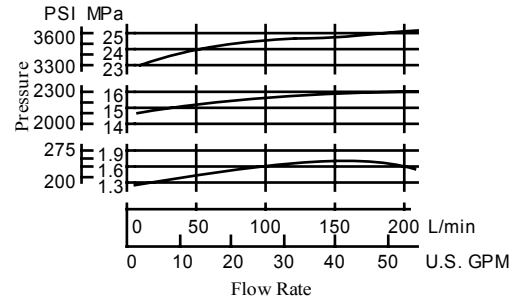

BT-10, BG-10

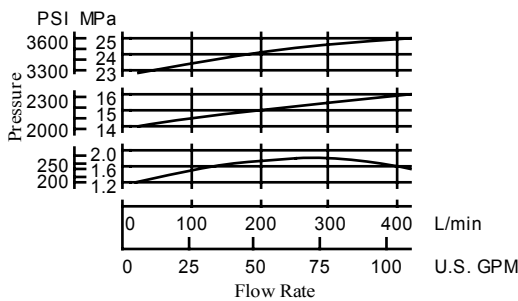

Min. Adj. Pressure & Vent Pressure vs. Flow

Hydraulic fluid: Viscosity : 35 mm²/s (164 SSU)
Specific Gravity : 0.850

BT-03, BG-03

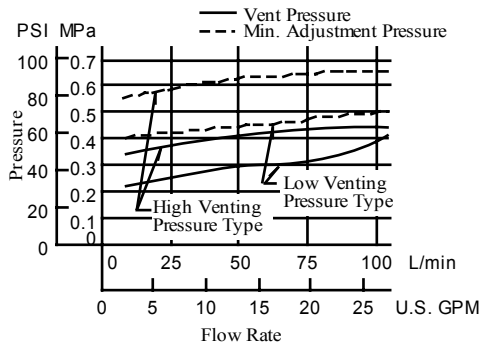

BT-06, BG-06

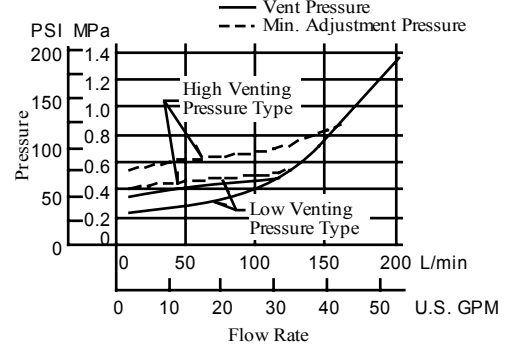

BT-10, BG-10

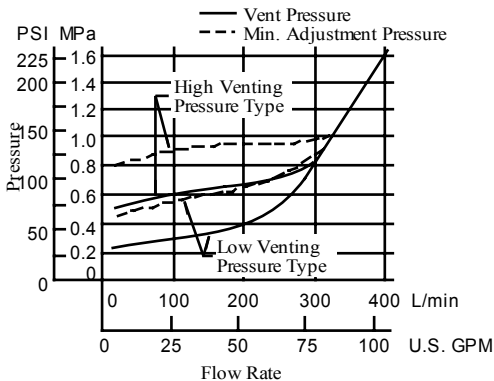

BT-03-* -32/3280/3290

BT-06-* -32/3280/3290

BT-10-* -32/3280/3290

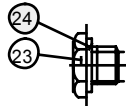
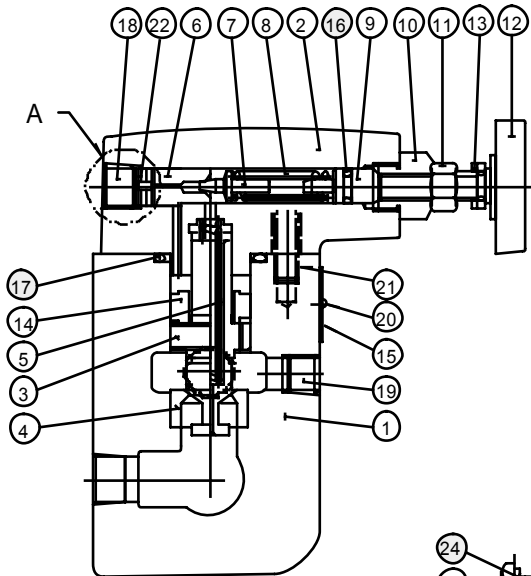

Section "A"
for Design 3280

CAUTION

When making replacement of seals, please do it carefully after reading through the relevant instructions in the Operator's Manual.

List of Seals

Item	Name of Parts	Part Numbers			Qty.
		BT-03	BT-06	BT-10	
16	O-Ring	SO-NA-P9	SO-NA-P9	SO-NA-P9	1
17	O-Ring	SO-NB-P32	SO-NB-P32	SO-NB-P42	1
24	Bonded Seal	SG-FB-3/8	SG-FB-3/8	SG-FB-3/8	1

Note: When ordering the seals, please specify the seal kit number from the table below.

List of Seal Kits

Model Numbers	Seal Kit Numbers
BT-03	KS-BT-03-32
BT-06	
BT-10	KS-BT-10-32

Note: No bonded seals are included in the seal kits.

BG-03-* -32/3290

BG-06-* -32/3290

BG-10-* -32/3290

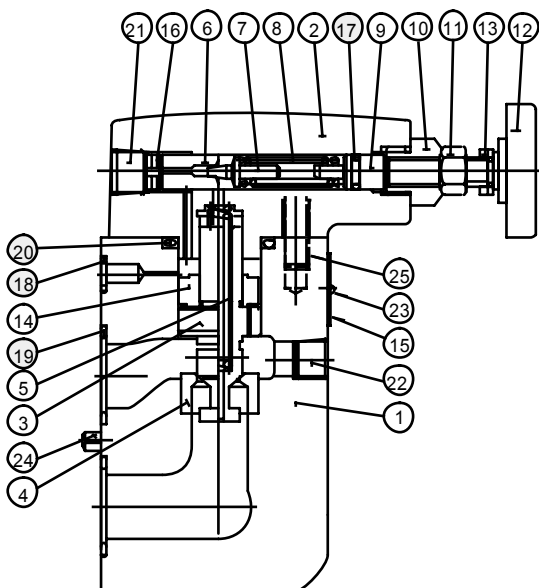

List of Seals

Item	Name of Parts	Part Numbers			Qty.
		BG-03	BG-06	BG-10	
17	O-Ring	SO-NA-P9	SO-NA-P9	SO-NA-P9	1
18	O-Ring	SO-NB-P9	SO-NB-P11	SO-NB-P9	1
19	O-Ring	SO-NB-P18	SO-NB-P28	SO-NB-P32	2
20	O-Ring	SO-NB-P32	SO-NB-P32	SO-NB-P42	1

Note: When ordering the seals, please specify the seal kit number from the table below.

List of Seal Kits

Model Numbers	Seal Kit Numbers
BG-03	KS-BG-03-32
BG-06	KS-BG-06-32
BG-10	KS-BG-10-32

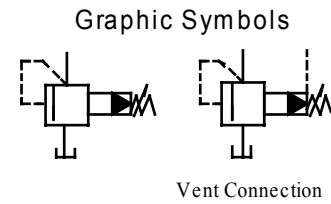
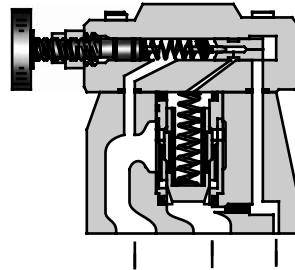

Specifications

Model Numbers	Max. Operating Pressure MPa (PSI)	Pres. Adj. Range MPa (PSI)	Max. Flow L/min (U.S.GPM)	Approx. Mass kg (lbs.)
S-BG-03-*-*-40	25 (3630)	Note)	100 (26.4)	4.1 (9.0)
S-BG-06-*-*-40		★-25	200 (52.8)	5.0 (11.0)
S-BG-10-*-*-40*		(★-3630)	400 (106)	10.5 (23.1)

Note: See minimum adjustment pressure characteristics on page 18.

Model Number Designation

F-	S-	B	G	-03	-V	-L	-40	*
Special Seals	Low Noise Type	Series Number	Type of Mounting	Valve Size	High Venting ^{*1} Pres. Feature	Direction of Handle	Design Number	Design Std.
F: Special Seals for Phosphate Ester Type Fluids (Omit if not required)	S: Low Noise Type	B: Pilot Operated Relief Valves	G: Sub-plate Mounting	03	V: For High Venting Pressure Feature (Omit if not required)	(Viewed from pressure gauge connection) L: Left (Normal) R: Right	40	Refer to ★2
				06			40	
				10			40	

★1. Use the high venting pressure type where it is necessary to reduce the response time from unloading to onloading.

★2. Design Standards: None Japanese Standard "JIS" and European Design Standard 90 N. American Design Standard

Sub-plate

Valve Model Numbers	Japanese Standard "JIS"		European Design Standard		N. American Design Standard		Approx. Mass kg (lbs.)
	Sub-plate Model Numbers	Thread Size	Sub-plate Model Numbers	Thread Size	Sub-plate Model Numbers	Thread Size	
S-BG-03	BGM-03-20	Rc 3/8	BGM-03-3080	3/8 BSP.F	BGM-03-2090	3/8 NPT	2.4 (5.3)
	BGM-03X-20	Rc 1/2	BGM-03X-3080	1/2 BSP.F	BGM-03X-2090	1/2 NPT	3.1 (6.8)
S-BG-06	BGM-06-20	Rc 3/4	BGM-06-3080	3/4 BSP.F	BGM-06-2090	3/4 NPT	4.7 (10.4)
	BGM-06X-20	Rc 1	BGM-06X-3080	1 BSP.F	BGM-06X-2090	1 NPT	5.7 (12.6)
S-BG-10	BGM-10-20	Rc 1-1/4	BGM-10-3080	1-1/4 BSP.F	BGM-10-2090	1-1/4 NPT	8.4 (18.5)
	BGM-10X-20	Rc 1-1/2	BGM-10X-3080	1-1/2 BSP.F	BGM-10X-2090	1-1/2 NPT	10.3 (22.7)

• Sub-plates are available. Specify the sub-plate model number from the table above. When sub-plates are not used, the mounting surface should have a good machined finish.

• The sub-plates are those for pilot operated relief valves. For dimensions, see page 13.

■ Attachment

● Mounting Bolts

Valve Model Numbers	Socket Head Cap Screw		Qty.
	Japanese Std. "JIS" and European Design Std.	N. American Design Std.	
S-BG-03	M12 × 40 Lg.	1/2-13 UNC × 1-1/2 Lg.	4
S-BG-06	M16 × 50 Lg.	5/8-11 UNC × 2 Lg.	4
S-BG-10	M20 × 60 Lg.	3/4-10 UNC × 2-1/4 Lg.	4

■ Instructions

- If a remote control relief valve is used in the vent circuit, see page 3. In addition, if the internal volume of the vent line is too large, chattering is likely to occur. Thus, as far as possible reduce the inside Dia. and the length of the pipe.
- Pressure is limited by collars fitted. If a working pressure cannot be attained, remove some collars. One collar is equivalent to 10 MPa (1450 PSI).
- With a small flow, the setting pressure may be unstable. Use models numbered 03 and 06 with a flow rate above 5 L/min (1.3 U.S. GPM) and model 10 with 8 L/min (2.1 U.S. GPM).

S-BG-03-* -L-40/4090
 S-BG-06-* -L-40/4090
 S-BG-10-* -40/4090

Mounting surface
 S-BG-03: ISO 6264-AR-06-2-A
 S-BG-06: ISO 6264-AS-08-2-A
 S-BG-10: ISO 6264-AT-10-2-A

DIMENSIONS IN MILLIMETRES (INCHES)

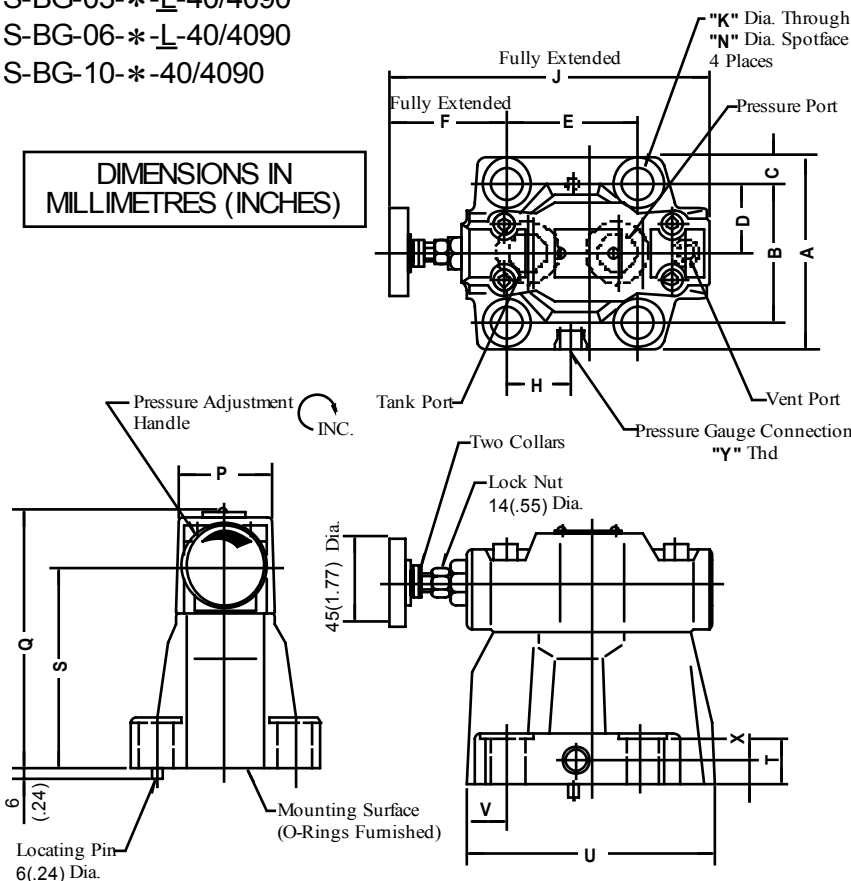

Opposite Handle Position

S-BG-03
 S-BG-06-* -R

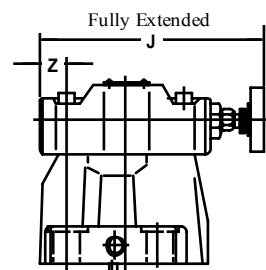

Note: For other dimensions, see the figures shown left.

Note: For dimensions of the valve mounting surface, see the dimensional drawing (P. 13) of the sub-plate used together.

Model Numbers	"Y" Thd.
S-BG-03-* -*-40	Rc 1/4 = 1/4 BSP.Tr
S-BG-03-* -*-4090	1/4 NPT
S-BG-06-* -*-40	Rc 1/4 = 1/4 BSP.Tr
S-BG-06-* -*-4090	1/4 NPT
S-BG-10-* -40	Rc 1/4 = 1/4 BSP.Tr
S-BG-10-* -4090	1/4 NPT

Model Numbers	Dimensions mm (Inches)																	
	A	B	C	D	E	F	H	J	K	N	P	Q	S	T	U	V	X	Z
S-BG-03	76 (2.99)	53.8 (2.12)	11.1 (.44)	26.9 (1.06)	53.8 (2.12)	73.6 (2.90)	26.9 (1.06)	163.5 (6.44)	13.5 (.53)	21 (.83)	50 (1.97)	130 (5.12)	103 (4.06)	21.5 (.85)	106 (4.17)	26.1 (1.03)	13 (.51)	36.1 (1.42)
S-BG-06	98 (3.86)	70 (2.76)	14 (.55)	35 (1.38)	66.7 (2.63)	58.8 (2.31)	33.7 (1.33)	163.5 (6.44)	17.5 (.69)	26 (1.02)	50 (1.97)	130 (5.12)	103 (4.06)	26 (1.02)	122 (4.80)	19.3 (.76)	13 (.51)	21.3 (.84)
S-BG-10	120 (4.72)	82.6 (3.25)	18.7 (.74)	41.3 (1.63)	88.9 (3.50)	50.6 (1.99)	44.9 (1.77)	180 (7.09)	21.5 (.85)	32 (1.26)	65 (2.56)	167 (6.57)	135 (5.31)	33.5 (1.32)	155 (6.10)	21.2 (.83)	18 (.71)	—

Nominal Override Characteristics

Hydraulic fluid:
 Viscosity : 35 mm²/s (164 SSU)
 Specific Gravity : 0.850

S-BG-03

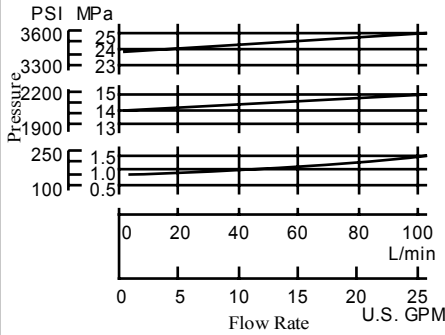

S-BG-06

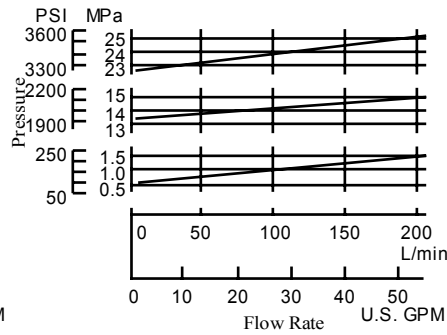

S-BG-10

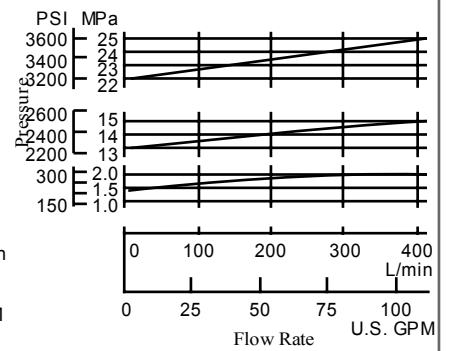

Mn. Adj. Pressure and Vent Pressure vs. Flow

Hydraulic fluid:
 Viscosity : 35 mm²/s (164 SSU)
 Specific Gravity : 0.850

— Vent Pressure
 - - - Min. Adjustment Pressure

S-BG-03

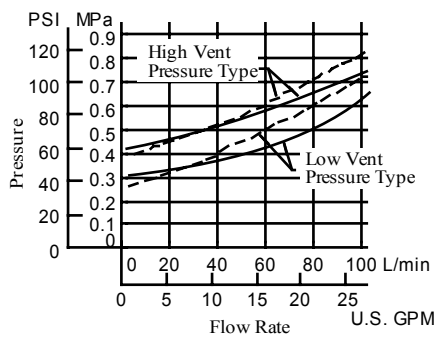

S-BG-06

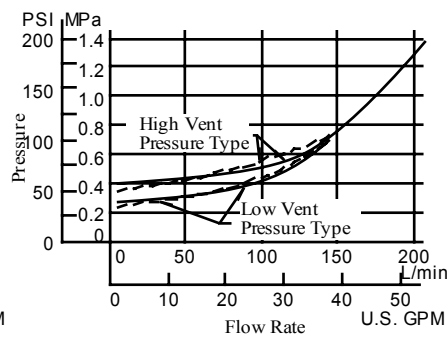

S-BG-10

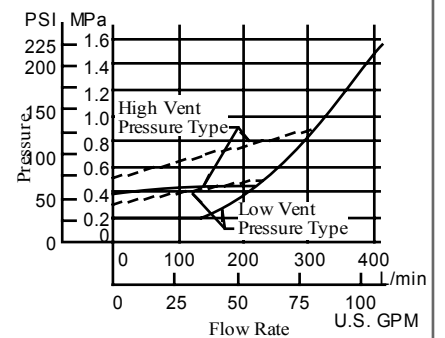

Noise Level

Measuring condition
 Measuring position: At 1m (3.3 ft.) back from the valve front.

Viscosity : 35 mm²/s (164 SSU)
 Backpressure : 0.1 MPa (14.5 PSI)

S-BG-03

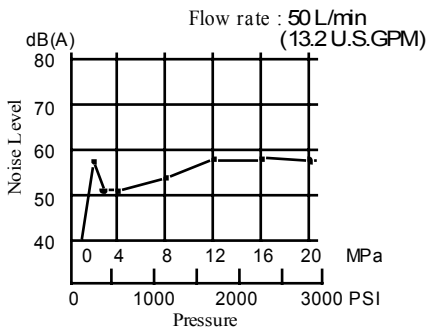

S-BG-06

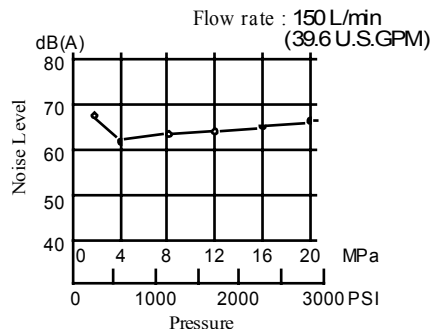

S-BG-10

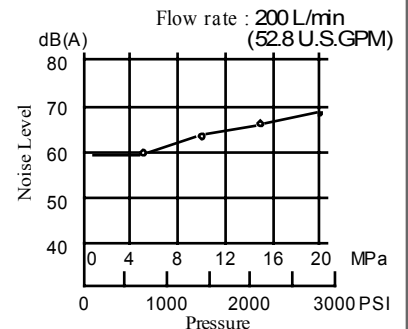

S-BG-03,06,10-* -40/4090

CAUTION

When making replacement of seals, please do it carefully after reading through the relevant instructions in the Operator's Manual.

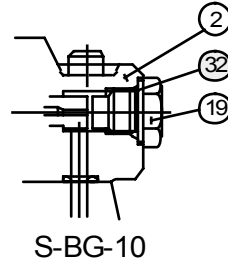
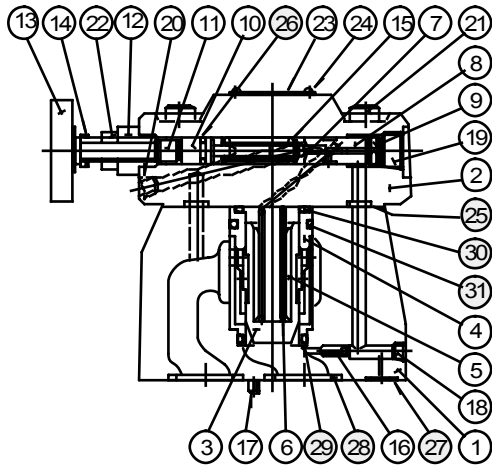

List of Seals

Item	Name of Parts	Part Numbers			Qty.
		S-BG-03	S-BG-06	S-BG-10	
25	O-Ring	SO-NB-P9	SO-NB-P9	SO-NB-P9	2
26	O-Ring	SO-NA-P9	SO-NA-P9	SO-NA-P9	1
27	O-Ring	SO-NB-P9	SO-NB-P11	SO-NB-P9	1
28	O-Ring	SO-NB-P18	SO-NB-P28	SO-NB-P32	2
29	O-Ring	SO-NB-A024	SO-NB-A024	SO-NB-A128	1
30	O-Ring	SO-NB-P28	SO-NB-P28	SO-NB-P36	1
31	O-Ring	SO-NB-P32	SO-NB-P32	SO-NB-P42	1
32	O-Ring	—	—	SO-NB-P14	1

List of Seal Kits

Model Numbers	Seal Kit Numbers
S-BG-03	KS-S-BG-03-40
S-BG-06	KS-S-BG-06-40
S-BG-10	KS-S-BG-10-40

Note: When ordering the seals, please specify the seal kit number from the table below.

Interchangeability in Installation between Conventional Type and Low-noise Type

The design 40 of low-noise S-BG-03, -06, and -10 is interchangeable for installation with design 32 of conventional BG-03, -06 and -10. Their exterior shapes such as the position of the pressure adjustment handles are different.

DIMENSIONS IN MILLIMETRES (INCHES)

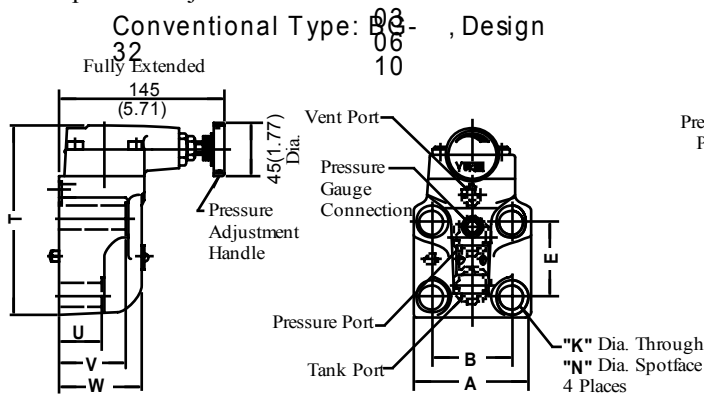

Low-noise type: S-BG-03, -06, -10, Design 40

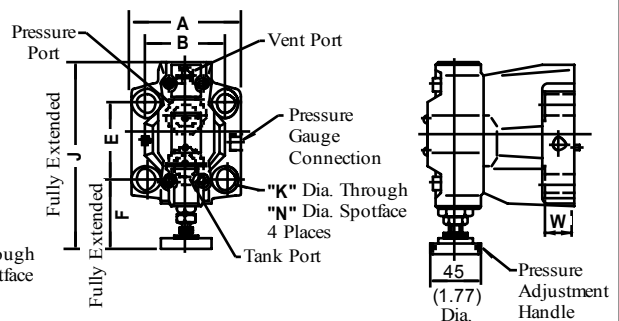

Model Numbers	A	B	E	K	N	T	U	V
BG-03	82 (3.23)	53.8 (2.12)	53.8 (2.12)	13.5 (.53)	21 (.83)	117 (4.61)	55 (2.16)	78 (3.07)
BG-06	104 (4.09)	70 (2.76)	66.7 (2.63)	17.5 (.69)	26 (1.02)	141 (5.55)	38 (1.50)	58 (2.28)
BG-10	124 (4.88)	82.6 (3.25)	88.9 (3.50)	21.5 (.85)	32 (1.26)	175 (6.89)	45 (1.77)	65 (2.56)

Model Numbers	A	B	E	F	K	N	J	W
S-BG-03	76 (2.99)	53.8 (2.12)	53.8 (2.12)	73.6 (2.90)	13.5 (.53)	21 (.83)	163.5 (6.44)	20.5 (.81)
S-BG-06	98 (3.86)	70 (2.76)	66.7 (2.63)	58.8 (2.31)	17.5 (.69)	26 (1.02)	163.5 (6.44)	25 (.98)
S-BG-10	120 (4.72)	82.6 (3.25)	88.9 (3.50)	50.6 (1.99)	21.5 (.85)	32 (1.26)	180 (7.09)	32.5 (1.28)

■ Specifications

Model Numbers		Max. Operating Pressure MPa (PSI)	Pressure Adj. Range MPa (PSI)	Max. Flow L/min (U.S.GPM)	Approx. Mass kg (lbs.)		
					Double Sol.	Single Sol.	With Vent Restrictor
Threaded Connection	BST-03-*-*-47	25 (3630)	Note) ★-25 (★-3630)	100 (26.4)	7.4 (16.3)	6.8 (15.0)	7.8 (17.2)
	*			200 (52.8)	7.4 (16.3)	6.8 (15.0)	7.8 (17.2)
	BST-06-*-*-47			400 (106)	11.1 (24.5)	10.5 (23.2)	11.5 (25.4)
Sub-plate Mounting	BSG-03-*-*-47	25 (3630)	Note) ★-25 (★-3630)	100 (26.4)	7.1 (15.7)	6.5 (14.3)	7.5 (16.5)
	*			200 (52.8)	8.0 (17.6)	7.4 (16.3)	8.4 (18.5)
	BSG-06-*-*-47			400 (106)	11.3 (24.9)	10.7 (23.6)	11.7 (25.8)



Note: For relief valves, standard pilot operated relief valves are used.
For minimum adjustment pressures and other characteristics, see page 14.

● Solenoid Ratings

Electric Source	Coil Type	Frequency (Hz)	Voltage (V)		Current & Power at Rated Voltage		
			Source Rating	Serviceable Range	Inrush* (A)	Holding (A)	Power (W)
AC	A100	50	100	80~110	2.42	0.51	—
			100	90~120	2.14	0.37	
			110		2.35	0.44	
	A120	60	120	96~132	2.02	0.42	
				108~144	1.78	0.31	
	A200	50	200	160~220	1.21	0.25	
			200	180~240	1.07	0.19	
	A240	60	220		1.18	0.22	
240			192~264	1.01	0.21		
DC (K Series)	D12	—	12	10.8~13.2	—	2.45	29
			24	21.6~26.4	—	1.23	
			48	43.2~52.8	—	0.61	
AC→DC Rectified	R100	50/60	100	90~110	—	0.33	29
			200	180~220	—	0.16	

* Inrush current in the above table shows rms values at maximum stroke.

The coil type numbers in the shaded column are handled as optional extras. In case these coils are required to be chosen, please confirm the time of delivery with us before ordering.

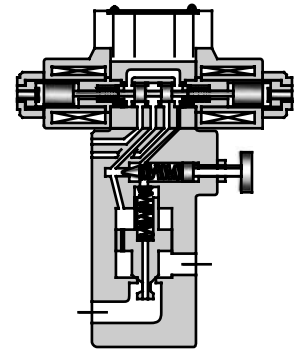

Yuken can offer flanged connection valves described below. Consult Yuken for the details.

Model Numbers	Max. Operating Pressure MPa (PSI)	Max. Flow L/min (U.S.GPM)
BSF-10-*-*-47*	25 (3630)	400 (106)
BSF-16-*-*-47*		800 (211)

■ Model Number Designation

F-	A-	BS	T	-03	-V	-2B3A	-A100	-N	-47	*
Special Seals	With Vent Restrictor	Series Number	Type of Mounting	Valve Size	High Venting Pres. Feature	Vent Type	Coil Type	Type of Electrical Con.	Design Number	Design Standards
F: Special Seals for Phosphate Ester Type Fluids (Omit if not required)	A: With Vent Restrictor (Option)	BS: Solenoid Controlled Relief Valves	T: Threaded Connection G: Sub-plate Mounting	03 06 10	V: For High Venting Pressure Feature (Omit if not required)	2B3A ^{★3} 2B3B 2B2B 2B2 3C2 3C3	AC: A100, A120 A200, A240 DC: D12, D24 D48 AC→DC: R100, R200	None: Terminal Box Type N: With Plug-in Connector (DIN) N: With Plug-in Connector (DIN)	47	None: Japanese Std. "JIS" 90: N. American Design Std. 80: European Design Std.

- ★1. Models with vent restrictor are applicable only for the vent type 2B3A and 2B3B. For details, see page 22.
- ★2. Use high-venting-pressure types to reduce response time from unloading to onloading.
- ★3. For the details of the vent types, see the following page.

■ Vent Types

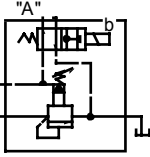
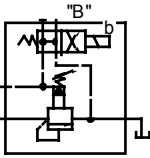
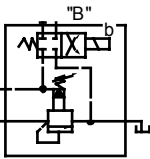
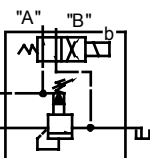
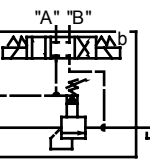
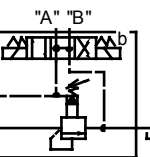
Vent Type	Graphic Symbols	Solenoid Operated Directional Valve Model Number	Operation		
			SOL "a"	SOL "b"	Vent Connecting
2B3A		DSG-01-2B3A	—	OFF	Connected to port "A".
				ON	Connected to tank (no-load)
2B3B		DSG-01-2B3B	—	OFF	Connected to tank (no-load)
				ON	Connected to port "B".
2B2B		DSG-01-2B2B	—	OFF	Closed state (relief valve setting pressure)
				ON	Connected to port "B".
2B2		DSG-01-2B2	—	OFF	Connected to port "A".
				ON	Connected to port "B".
3C2		DSG-01-3C2	OFF	OFF	Closed state (relief valve setting pressure)
			ON	OFF	Connected to port "A".
			OFF	ON	Connected to port "B".
3C3		DSG-01-3C3	OFF	OFF	Connected to tank (no-load)
			ON	OFF	Connected to port "A".
			OFF	ON	Connected to port "B".

■ Attachment

● Mounting Bolts

Valve Model Numbers	Socket Head Cap Screw	
	Japanese Std. "JIS" and European Design Std.	N. American Design Std.
BSG-03	M12 × 70 Lg. (2 pcs.), M12 × 95 Lg. (2 pcs.)	1/2-13UNC × 2-3/4 Lg. (2 pcs.), 1/2-13UNC × 3-3/4 Lg. (2 pcs.)
BSG-06	M16 × 60 Lg. (2 pcs.), M16 × 80 Lg. (2 pcs.)	5/8-11UNC × 2-1/4 Lg. (2 pcs.), 5/8-11UNC × 3-1/4 Lg. (2 pcs.)
BSG-10	M20 × 70 Lg. (2 pcs.), M20 × 90 Lg. (2 pcs.)	3/4-10UNC × 2-3/4 Lg. (2 pcs.), 3/4-10UNC × 3-1/2 Lg. (2 pcs.)

■ Sub-plate

Valve Model Numbers	Japanese Standard "JIS"		European Design Standard		N. American Design Standard		Approx. Mass kg (lbs.)
	Sub-plate Model Numbers	Thread Size	Sub-plate Model Numbers	Thread Size	Sub-plate Model Numbers	Thread Size	
BSG-03	BGM-03-20	Rc 3/8	BGM-03-3080	3/8 BSP.F	BGM-03-2090	3/8 NPT	2.4(5.3)
	BGM-03X-20	Rc 1/2	BGM-03X-3080	1/2 BSP.F	BGM-03X-2090	1/2 NPT	3.1(6.8)
BSG-06	BGM-06-20	Rc 3/4	BGM-06-3080	3/4 BSP.F	BGM-06-2090	3/4 NPT	4.7(10.4)
	BGM-06X-20	Rc 1	BGM-06X-3080	1 BSP.F	BGM-06X-2090	1 NPT	5.7(12.6)
BSG-10	BGM-10-20	Rc 1-1/4	BGM-10-3080	1-1/4 BSP.F	BGM-10-2090	1-1/4 NPT	8.4(18.5)
	BGM-10X-20	Rc 1-1/2	BGM-10X-3080	1-1/2 BSP.F	BGM-10X-2090	1-1/2 NPT	10.3(22.7)

- Sub-plates are available. Specify the sub-plate model number from the table above. When sub-plates are not used, the mounting surface should have a good machined finish.
- The sub-plates are those for pilot operated relief valves. For dimensions, see page 13.

■ Option

● Models with vent restrictor

The type with a vent restrictor has a vent restrictor in vent types 2B3A and 2B3B added between a relief valve and a solenoid operated directional valve. It prevents shock to the main circuit by gradually lowering the venting pressure in the shift from the set pressure to unloading. Unloading pressure are the same as without a vent restrictor.

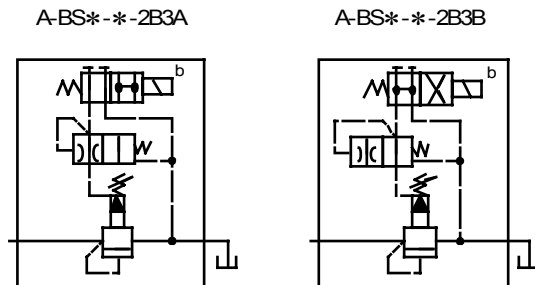

■ Instructions

- If a remote control relief valve is used in the vent circuit, see page 3. In addition, if the internal volume of the vent line is too large, chattering is likely to occur. Thus, as far as possible reduce the inside Dia. and the length of the pipe.
- Pressure is limited by collars fitted. If a working pressure cannot be attained, remove some collars. One collar is equivalent to 10 MPa (1450 PSI).
- With a small flow, the setting pressure may be unstable. Use models numbered 03 and 06 with a flow rate above 8 L/min (2.1 U.S. GPM) and model 10 with 15 L/min (4.0 U.S. GPM).
- There are two threaded connection pressure ports. They can be connected each other in-line; one as inlet and the other as an outlet or the valve can be used by plugging one of the pressure ports.

■ Interchangeability in Installation between Old and New Design.

Design 47 valve is one on which DSG-01, design 60 is mounted as a pilot valve. It is interchangeable with old design (design 46) with respect to specifications, exterior shape and mounting dimensions.

● Models with Plug-in Connector

03
BST-06-*-**-N-47/4780/4790
10

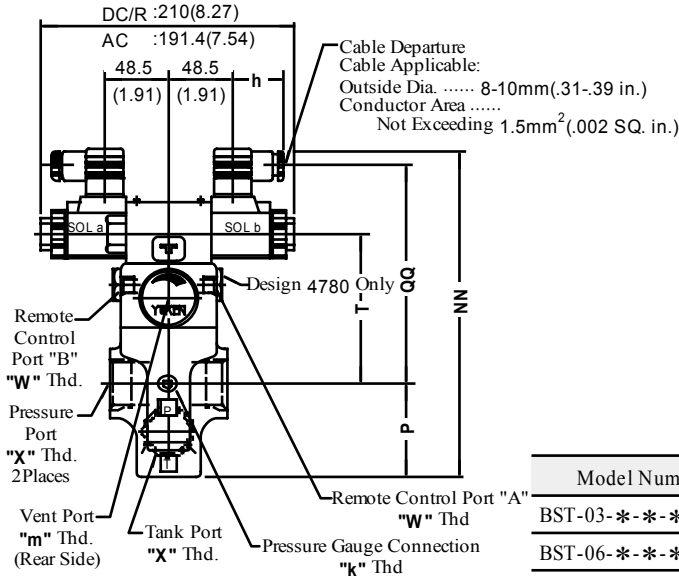

**DIMENSIONS IN
MILLIMETRES (INCHES)**

Model Numbers	Dimensions mm (Inches)				
	P	T	NN	QQ	h
BST-03-*-A*-N	68.5 (2.70)	107 (4.21)	240.5 (9.47)	160 (6.30)	39 (1.54)
BST-06-*-A*-N					
BST-10-*-A*-N	89 (3.50)	119 (4.69)	273 (10.75)	172 (6.77)	
BST-03-*-D*-N	68.5 (2.70)	107 (4.21)	251.5 (9.90)	171 (6.73)	39 (1.54)
BST-06-*-D*-N					
BST-10-*-D*-N	89 (3.50)	119 (4.69)	284 (11.18)	183 (7.20)	
BST-03-*-R*-N	68.5 (2.70)	107 (4.21)	254.5 (10.02)	164.2 (6.46)	53 (2.09)
BST-06-*-R*-N					
BST-10-*-R*-N	89 (3.50)	119 (4.69)	287 (11.30)	176.2 (6.94)	

Model Numbers	"W" Thd.	"X" Thd.	"k" Thd.	"m" Thd.
BST-03-*-**-N-4780		3/8 BSP.F		
BST-06-*-**-N-4780	1/8 BSP.F	3/4 BSP.F	1/4 BSP.Tr	3/8 BSP.Tr
BST-10-*-**-N-4780		1-1/4 BSP.F		

See the installation drawing of terminal box type on page 23 for design 47 and 4790 port screws and other dimensions.

■ Options - Models with Vent Restrictor

● Terminal Box Type

03
A-BST-06-*-2B3A-*-47/4790
10
2B3B

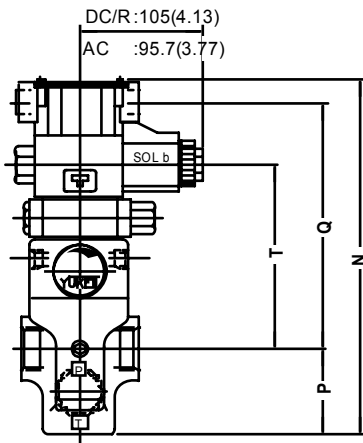

● Plug-in Connector Type

03
A-BST-06-*-2B3A-*-N-47/4780/4790
10
2B3B

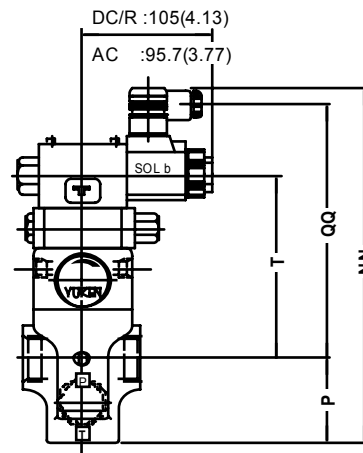

Item	P	T	Terminal Box Type		Plug-in Connector Type					
					AC Solenoid		DC Solenoid		R (AC→DC) Solenoid	
			N	Q	NN	QQ	NN	QQ	NN	QQ
A-BST-03	68.5 (2.70)	137 (5.39)	270.8 (10.66)	184 (7.24)	270.5 (10.65)	190 (7.48)	281.5 (11.08)	201 (7.91)	284.5 (11.20)	194.2 (7.65)
A-BST-06										
A-BST-10	89 (3.50)	149 (5.87)	303.3 (11.94)	196 (7.72)	303 (11.93)	202 (7.95)	314 (12.36)	213 (8.39)	317 (12.48)	206.2 (8.12)

For other dimensions, see the models without vent restrictor type on page 23 and 24.

BSG-03-* -47/4790
BSG-06-* -47/4790
BSG-10-* -47/4790

Mounting surface
BSG-03: ISO 6264-AR-06-2-A
BSG-06: ISO 6264-AS-08-2-A
BSG-10: ISO 6264-AT-10-2-A

● Terminal Box Type

DIMENSIONS IN
MILLIMETRES (INCHES)

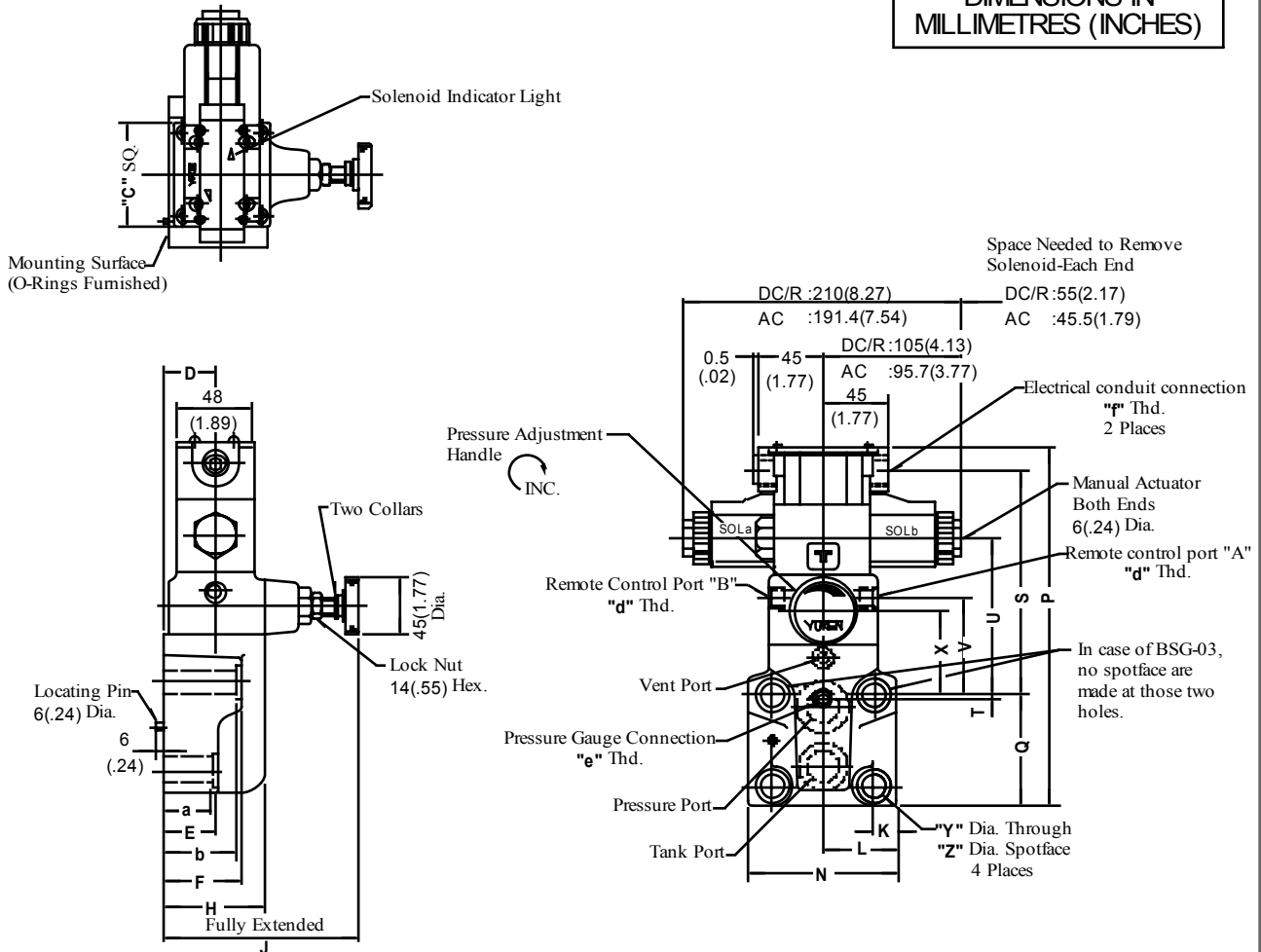

Model Numbers	Dimensions mm (Inches)																			
	C	D	E	F	H	J	K	L	N	P	Q	S	T	U	V	X	Y	Z	a	b
BSG-03	75 (2.95)	40 (1.57)	57 (2.24)	78 (3.07)	78 (3.07)	145 (5.71)	14.1 (.56)	41 (1.61)	82 (3.23)	227.3 (8.95)	77 (3.03)	132 (5.20)	22 (.87)	85 (3.35)	47 (1.85)	40 (1.57)	13.5 (.53)	21 (.83)	55 (2.17)	—
BSG-06	75 (2.95)	40 (1.57)	40 (1.57)	60 (2.36)	78 (3.07)	145 (5.71)	17 (.67)	52 (2.05)	104 (4.09)	251.3 (9.89)	83.5 (3.29)	149.5 (5.89)	4.5 (.18)	102.5 (4.04)	64.5 (2.54)	57.5 (2.26)	17.5 (.69)	26 (1.02)	38 (1.50)	58 (2.28)
BSG-10	85 (3.35)	45 (1.77)	47 (1.85)	67 (2.64)	84 (3.31)	146 (5.75)	20.7 (.81)	62 (2.44)	124 (4.88)	285.3 (11.23)	110 (4.33)	157 (6.18)	6 (.24)	110 (4.33)	72 (2.83)	65 (2.56)	21.5 (.85)	32 (1.26)	45 (1.77)	65 (2.56)

Model Numbers	Japanese Standard "JIS" Design 47			N. American Design Standard Design 4790		
	"d" Thd.	"e" Thd.	"f" Thd.	"d" Thd.	"e" Thd.	"f" Thd.
BSG-03						
BSG-06	Rc 1/8	Rc 1/4	G 1/2	1/8 NPT	1/4 NPT	1/2 NPT
BSG-10						

Note: For dimensions of the valve mounting surface, see the installation drawing (P.13) of the sub-plate used together.

● Models with Plug-in Connector

03
BSG-06-**-**-N-47/4780/4790
10

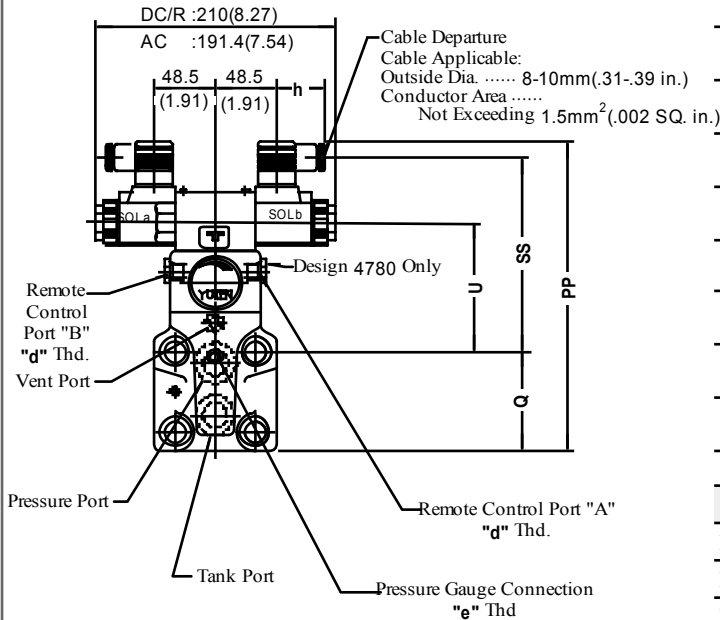

DIMENSIONS IN
MILLIMETRES (INCHES)

Model Numbers	Dimensions mm (Inches)				
	Q	U	PP	SS	h
BSG-03-**-A*-N	77 (3.03)	85 (3.35)	227 (8.94)	138 (5.43)	39 (1.54)
BSG-06-**-A*-N	83.5 (3.29)	102.5 (4.04)	251 (9.88)	155.5 (6.12)	
BSG-10-**-A*-N	110 (4.33)	110 (4.33)	285 (11.22)	163 (6.42)	
BSG-03-**-D*-N	77 (3.03)	85 (3.35)	238 (9.37)	149 (5.87)	39 (1.54)
BSG-06-**-D*-N	83.5 (3.29)	102.5 (4.04)	262 (10.31)	166.5 (6.56)	
BSG-10-**-D*-N	110 (4.33)	110 (4.33)	296 (11.65)	174 (6.85)	
BSG-03-**-R*-N	77 (3.03)	85 (3.35)	241 (9.49)	142.2 (5.60)	53 (2.09)
BSG-06-**-R*-N	83.5 (3.29)	102.5 (4.04)	265 (10.43)	159.7 (6.29)	
BSG-10-**-R*-N	110 (4.33)	110 (4.33)	299 (11.77)	167.2 (6.58)	

Model Numbers	"d" Thd.	"e" Thd.
BSG-03-**-**-N-4780	1/8 BSP.F	1/4 BSP.Tr
BSG-06-**-**-N-4780		
BSG-10-**-**-N-4780		

See the installation drawing of terminal box type on page 25 for design 47 and 4790 port screws and other dimensions.

■ Options - Models with Vent Restrictor

● Terminal Box Type

03
A-BSG-06-**-2B3A-**-47/4790
10
2B3B

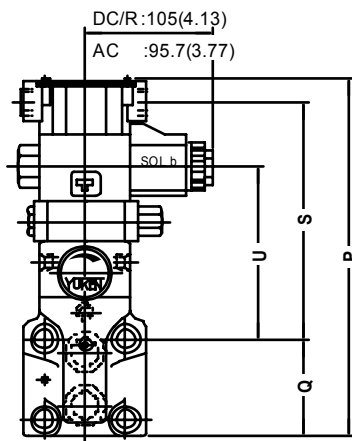

● Plug-in Connector Type

03
A-BSG-06-**-2B3A-**-N-47/4780/4790
10
2B3B

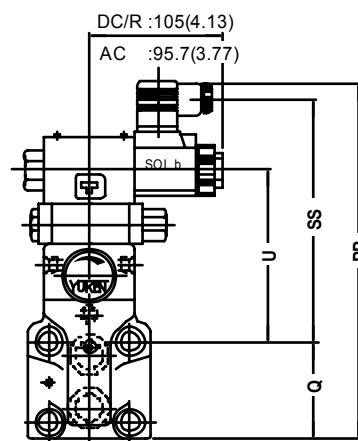

Item Model Numbers	Q	U	Terminal Box Type		Plug-in Connector Type					
			P	S	AC Solenoid		DC Solenoid		R (AC→DC) Solenoid	
					PP	SS	PP	SS	PP	SS
A-BSG-03	77 (3.03)	115 (4.53)	257.3 (10.13)	162 (6.38)	257 (10.12)	168 (6.61)	268 (10.55)	179 (7.05)	271 (10.67)	172.2 (6.78)
A-BSG-06	83.5 (3.29)	132.5 (5.22)	281.3 (11.07)	179.5 (7.07)	281 (11.06)	185.5 (7.30)	292 (11.50)	196.5 (7.74)	295 (11.61)	189.7 (7.47)
A-BSG-10	110 (4.33)	140 (5.51)	315.3 (12.41)	187 (7.36)	315 (12.40)	193 (7.60)	326 (12.83)	204 (8.03)	329 (12.95)	197.2 (7.76)

For other dimensions, see the models without vent restrictor type on page 25 and 26.

Details of Receptacle

Type of Electrical Conduit Connection	Double Solenoid Type	Single Solenoid Type
Terminal Box Type		
Plug-in Connector Type		

- ★ 1. There are two grounding terminals. You can use either one.
- ★ 2. If you do not need the common plate, remove it.
- ★ 3. With DC solenoids, polarity is no question.

DANGER

- Do not perform wiring while the power is on. Doing so may result in electric shock, burns or death.
- Make the wiring properly. Improper wiring will cause an irregular movement of the machine, resulting in a grave accident.

Electrical Circuit

Type of Electrical Conduit Connection	Electric Source		
	AC	DC	AC → DC Rectified
Terminal Box Type			
Plug-in Connector Type			

■ Threaded Connections

● Terminal Box Type

03
BST- 06-**-**-47/4790
10

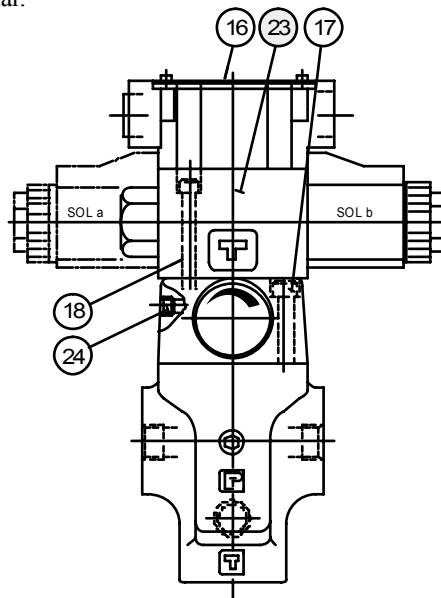
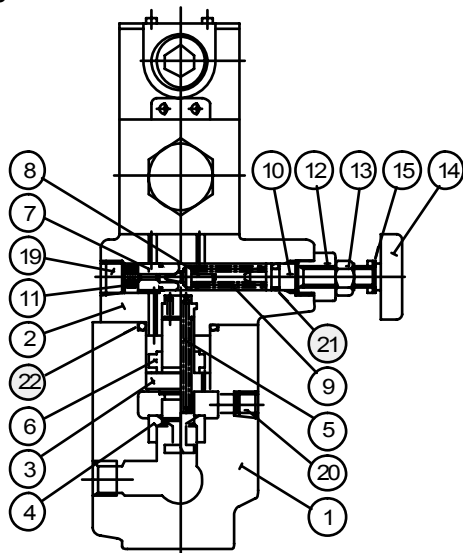

⚠ CAUTION

When making replacement of seals or solenoid assemblies, please do it carefully after reading through the relevant instructions in the Operator's Manual.

● Models with Plug-in Connector

03
BST- 06-**-**-N-47/4780/4790
10

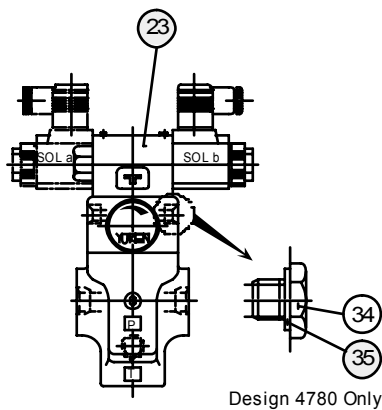

■ Option

● Models with Vent Restrictor

03
A-BST- 06-**-**-47/4790
10
N-47/4780/4790

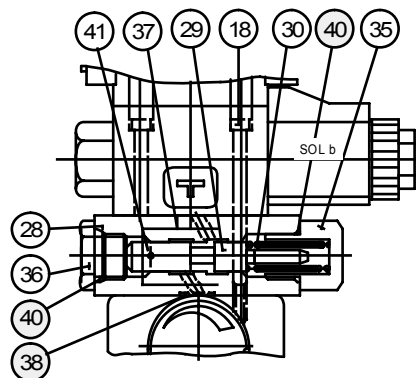

● List of Seals

Item	Name of Parts	Part Numbers			Qty.
		BST-03	BST-06	BST-10	
21	O-Ring	SO-NA-P9	SO-NA-P9	SO-NA-P9	1
22	O-Ring	SO-NB-P32	SO-NB-P32	SO-NB-P42	1
35	Bonded Seal	SG-FB-1/8	SG-FB-1/8	SG-FB-1/8	2
38*	O-Ring	SO-NB-P8			2
40*	O-Ring	SO-NB-P14			2

★ The O-Rings for Item 38,40 are used only for the models with the vent restrictor.

Note: When ordering the seals, please specify the seal kit number from the table right. In addition to the above seals, seals for the pilot valves are included in the seal kit.

For the detail of the pilot valve seals, see the catalogue No. Pub.EC-0402.

● List of Seal Kits

Model Numbers	Seal Kit Numbers
BST-03	KS-BST-03-46
BST-06	
BST-10	KS-BST-10-46
A-BST-03	KS-A-BST-03-46
A-BST-06	
A-BST-10	KS-A-BST-10-46

Note: No bonded seals are included in the seal kits.

● Pilot Valves

See page 30 for the pilot valve model numbers to be used.

■ Sub-plate Mounting

● Terminal Box Type

03
BSG-06-**-**-47/4790
10

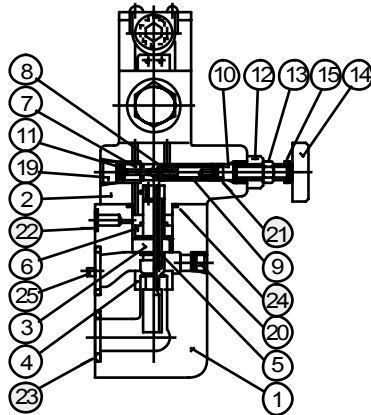

⚠ CAUTION

When making replacement of seals or solenoid assemblies, please do it carefully after reading through the relevant instructions in the Operator's Manual.

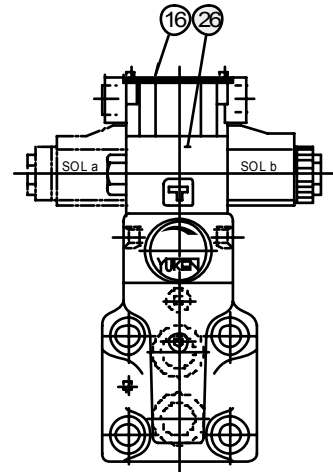

● Models with Plug-in Connector

03
BSG-06-**-**-N-47/4780/4790
10

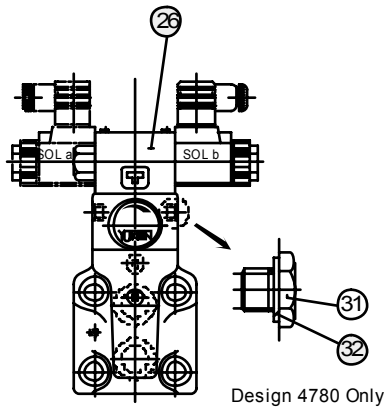

■ Option

● Models with Vent Restrictor

03
A-BSG-06-**-**-47/4790
10
N-47/4780/4790

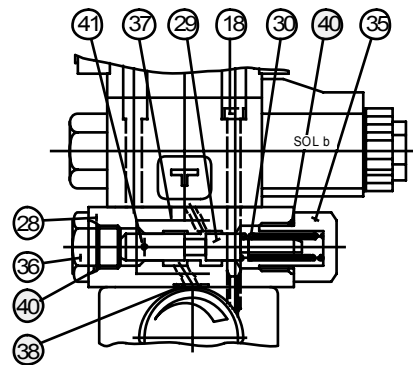

● List of Seals

Item	Name of Parts	Part Numbers			Qty.
		BSG-03	BSG-06	BSG-10	
21	O-Ring	SO-NA-P9	SO-NA-P9	SO-NA-P9	1
22	O-Ring	SO-NB-P9	SO-NB-P11	SO-NB-P9	1
23	O-Ring	SO-NB-P18	SO-NB-P28	SO-NB-P32	2
24	O-Ring	SO-NB-P32	SO-NB-P32	SO-NB-P42	1
32	Bonded Seal	SG-FB-1/8	SG-FB-1/8	SG-FB-1/8	2
38*	O-Ring	SO-NB-P8			2
40*	O-Ring	SO-NB-P14			2

★ The O-Rings for item 38, 40 are used only for the models with the vent restrictor.

Note: When ordering the seals, please specify the seal kit number from the table right. In addition to the above seals, seals for the pilot valves are included in the seal kit. For the detail of the pilot valve seals, see the catalogue No. Pub. EC-0402.

● List of Seal Kits

Model Numbers	Seal Kit Numbers
BSG-03	KS-BSG-03-46
BSG-06	KS-BSG-06-46
BSG-10	KS-BSG-10-46
A-BSG-03	KS-A-BSG-03-46
A-BSG-06	KS-A-BSG-06-46
A-BSG-10	KS-A-BSG-10-46

Note: No bonded seals are included in the seal kits.

● Pilot Valves

See page 30 for the pilot valve model numbers to be used.

Spare Parts List

● List of Pilot Valves

Type of Electrical Conduit Connection	Valve Model Numbers	Pilot Valve Model Numbers	Remarks
Terminal Box Type	*-BST/BSG-03/06/10-*2B3A-★-47	DSG-01-2B3A-★-60	Japanese Standard "JIS"
	*-BST/BSG-03/06/10-*2B3B-★-47	DSG-01-2B3B-★-60	
	*-BST/BSG-03/06/10-*2B2B-★-47	DSG-01-2B2B-★-60	
	*-BST/BSG-03/06/10-*2B2-★-47	DSG-01-2B2-★-60	
	*-BST/BSG-03/06/10-*3C2-★-47	DSG-01-3C2-★-60	
	*-BST/BSG-03/06/10-*3C3-★-47	DSG-01-3C3-★-60	N. American Design Std.
	*-BST/BSG-03/06/10-*2B3A-★-4790	DSG-01-2B3A-★-6090	
	*-BST/BSG-03/06/10-*2B3B-★-4790	DSG-01-2B3B-★-6090	
	*-BST/BSG-03/06/10-*2B2B-★-4790	DSG-01-2B2B-★-6090	
	*-BST/BSG-03/06/10-*2B2-★-4790	DSG-01-2B2-★-6090	
*-BST/BSG-03/06/10-*3C2-★-4790	DSG-01-3C2-★-6090	Japanese Standard "JIS"	
*-BST/BSG-03/06/10-*3C3-★-4790	DSG-01-3C3-★-6090		
*-BST/BSG-03/06/10-*2B3A-★-N-47	DSG-01-2B3A-★-N-60		
*-BST/BSG-03/06/10-*2B3B-★-N-47	DSG-01-2B3B-★-N-60		
*-BST/BSG-03/06/10-*2B2B-★-N-47	DSG-01-2B2B-★-N-60		
*-BST/BSG-03/06/10-*2B2-★-N-47	DSG-01-2B2-★-N-60	European Design Std.	
*-BST/BSG-03/06/10-*3C2-★-N-47	DSG-01-3C2-★-N-60		
*-BST/BSG-03/06/10-*3C3-★-N-47	DSG-01-3C3-★-N-60		
*-BST/BSG-03/06/10-*2B3A-★-N-4780	DSG-01-2B3A-★-N-60		
*-BST/BSG-03/06/10-*2B3B-★-N-4780	DSG-01-2B3B-★-N-60		
*-BST/BSG-03/06/10-*2B2B-★-N-4780	DSG-01-2B2B-★-N-60	N. American Design Std.	
*-BST/BSG-03/06/10-*2B2-★-N-4780	DSG-01-2B2-★-N-60		
*-BST/BSG-03/06/10-*3C2-★-N-4780	DSG-01-3C2-★-N-60		
*-BST/BSG-03/06/10-*3C3-★-N-4780	DSG-01-3C3-★-N-60		
*-BST/BSG-03/06/10-*2B3A-★-N-4790	DSG-01-2B3A-★-N-6090		
*-BST/BSG-03/06/10-*2B3B-★-N-4790	DSG-01-2B3B-★-N-6090	N. American Design Std.	
*-BST/BSG-03/06/10-*2B2B-★-N-4790	DSG-01-2B2B-★-N-6090		
*-BST/BSG-03/06/10-*2B2-★-N-4790	DSG-01-2B2-★-N-6090		
*-BST/BSG-03/06/10-*3C2-★-N-4790	DSG-01-3C2-★-N-6090		
*-BST/BSG-03/06/10-*3C3-★-N-4790	DSG-01-3C3-★-N-6090		

Note: 1. Fill a coil type (a symbol representing current/voltage) in section marked ★ .
2. For the details of the pilot valves, see the Catalogue No. Pub. EC-0402.

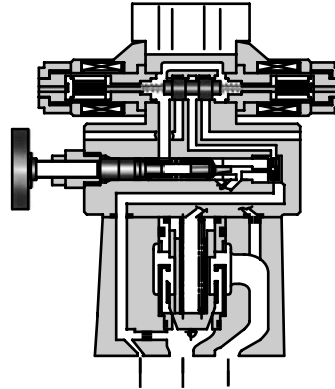

Specifications

Model Numbers		Max. Operating Pressure MPa (PSI)	Pressure Adj. Range MPa (PSI)	Max. Flow L/min (U.S.GPM)	Approx. Mass kg (lbs.)		
					Double Sol.	Single Sol.	With Vent Restrictor
Sub-plate Mounting	S-BSG-03-*-*-52*	25 (3630)	★ - 25 (★ - 3630)	100 (26.4)	6.3 (13.9)	5.7 (12.6)	6.7 (14.8)
	S-BSG-06-*-*-52*			200 (52.8)	7.2 (15.9)	6.6 (14.6)	7.6 (16.8)
	S-BSG-10-*-*-52*			400 (106)	12.7 (28.0)	12.1 (26.7)	13.1 (28.9)

★ For relief valves, low-noise type pilotoperated relief valves are used. For minimum adjustment pressures and other characteristics, see page 18.

Solenoid Ratings

Solenoid ratings are the same as for the conventional type. See Solenoid Ratings on page 20.

Model Number Designation

F-	A-	S-	BS	G	-03	-V	-2B3A	-A100	-N	-L	52	*
Special Seals	With Vent Restrictor	Low Noise Type	Series Number	Type of Mtg.	Valve size	High Venting Pres. Feature	Vent Type	Coil Type	Type of Electrical Connections	Direction of Handle	Design Number	Design Standards
F: Special Seals for Phosphate Ester Type Fluids (Omit if not required)	A: *1 With Vent Restrictor (option)	S: Low Noise Type	BS: Solenoid Controlled Relief Valves	G: Sub-plate Mtg.	03 06 10	V: *2 For High Venting Pressure Feature (Omit if not required)	2B3A 2B3B 2B2B 2B2 3C2 3C3	AC: *4 A100 A120 A200 A240 DC: D12 D24 D48 AC →DC: R100 R200	None: Terminal Box Type N: With Plug-in Connector (DIN) N: With Plug-in Connector (DIN)	(Viewed from pressure gauge Connection) L: Left (Normal) R: Right	52	None: Japanese Std. "JIS" 90: N. American Design Std. 80: European Design Std.

★ 1. Models with vent restrictor are applicable only for the vent type 2B3A and 2B3B. For details, see page 32.

★ 2. Use high-venting-pressure types to reduce response time from unloading to onloading.

★ 3. The vent types are the same as for the conventional type solenoid controlled relief valves. For the details of the vent types, see page 21.

★ 4. The coil codes are the same as for the conventional type solenoid controlled valves. See the solenoid ratings on page 20.

Option

Models with vent restrictor

The type with a vent restrictor has a vent restrictor in vent types 2B3A and 2B3B added between a relief valve and a solenoid operated directional valve. It prevents shock to the main circuit by gradually lowering the venting pressure in the shift from the setting pressure to unloading.

Unloading pressures are the same as without a vent restrictor.

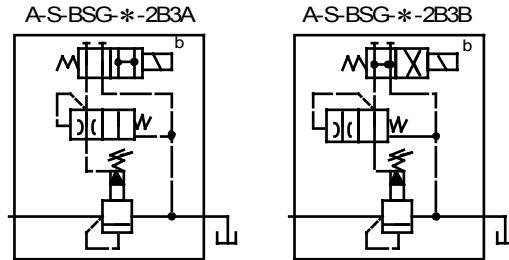

Sub-plate

Valve Model Numbers	Japanese Standard "JIS"		European Design Standard		N. American Design Standard		Approx. Mass kg (lbs.)
	Sub-plate Model Numbers	Thread Size	Sub-plate Model Numbers	Thread Size	Sub-plate Model Numbers	Thread Size	
S-BSG-03	BGM-03-20	Rc 3/8	BGM-03-3080	3/8 BSP.F	BGM-03-2090	3/8 NPT	2.4(5.3)
	BGM-03X-20	Rc 1/2	BGM-03X-3080	1/2 BSP.F	BGM-03X-2090	1/2 NPT	3.1(6.8)
S-BSG-06	BGM-06-20	Rc 3/4	BGM-06-3080	3/4 BSP.F	BGM-06-2090	3/4 NPT	4.7(10.4)
	BGM-06X-20	Rc 1	BGM-06X-3080	1 BSP.F	BGM-06X-2090	1 NPT	5.7(12.6)
S-BSG-10	BGM-10-20	Rc 1-1/4	BGM-10-3080	1-1/4 BSP.F	BGM-10-2090	1-1/4 NPT	8.4(18.5)
	BGM-10X-20	Rc 1-1/2	BGM-10X-3080	1-1/2 BSP.F	BGM-10X-2090	1-1/2 NPT	10.3(22.7)

• Sub-plates are available. Specify the sub-plate model number from the table above. When sub-plates are not used, the mounting surface should have a good machined finish.

• The sub-plates are those for pilot operated relief valves. For dimensions, see page 13.

Attachment

Mounting Bolts

Valve Model Numbers	Socket Head Cap Screw		Qty.
	Japanese Std. "JIS" and European Design Std.	N. American Design Std.	
S-BSG-03	M12 × 40 Lg.	1/2-13 UNC × 1-1/2 Lg.	4
S-BSG-06	M16 × 50 Lg.	5/8-11 UNC × 2 Lg.	4
S-BSG-10	M20 × 60 Lg.	3/4-10 UNC × 2-1/4 Lg.	4

Instructions

- If a remote control relief valve is used in the vent circuit, see page 3. In addition, if the internal volume of the vent line is too large, chattering is likely to occur. Thus, as far as possible reduce the inside Dia. and the length of the pipe.
- Pressure is limited by collars fitted. If a working pressure cannot be attained, remove some collars. One collar is equivalent to 10 MPa (1450 PSI).
- With a small flow, the setting pressure may be unstable. Use models numbered 03 and 06 with a flow rate above 5 L/min (1.3 U.S. GPM) and model 10 with 8 L/min (2.1 U.S. GPM).

Terminal Box Type

Opposite Handle Position

S-BSG-03-**-**-**-R
06

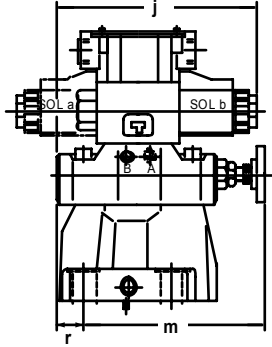

Note: For other dimensions, see the figures shown right

Mounting surface
S-BSG-03: ISO 6264-AR-06-2-A
S-BSG-06: ISO 6264-AS-08-2-A
S-BSG-10: ISO 6264-AT-10-2-A

S-BSG-03-**-**-**-L-52/5290
06
S-BSG-10-**-**-**-L-52/5290

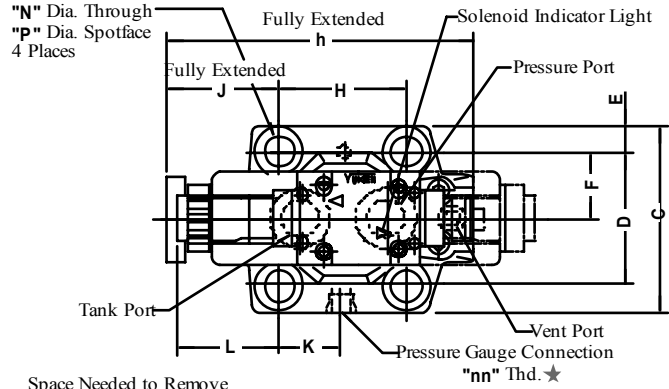

Space Needed to Remove Solenoid-Each End

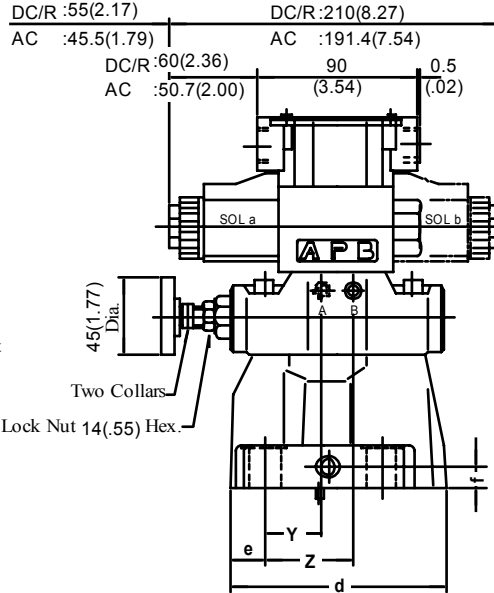

Electrical Conduit Connection

Design Std.	Thd. Size
52	G 1/2
5290	1/2 NPT

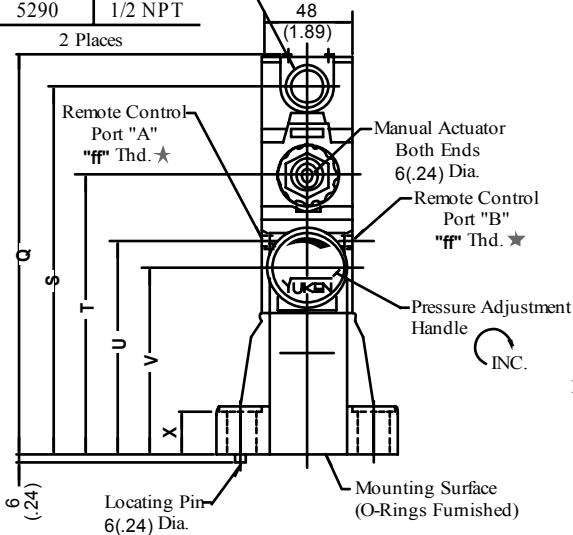

Model Numbers	Dimensions mm (Inches)																						
	C	D	E	F	H	J	K	N	P	Q	S	T	U	V	X	Y	Z	d	e	f	h	m	r
S-BSG-03	76 (2.99)	53.8 (2.12)	11.1 (.44)	26.9 (1.06)	53.8 (2.12)	73.6 (2.90)	26.9 (1.06)	13.5 (.53)	21 (.83)	218.3 (8.59)	200 (7.87)	153 (6.02)	117 (4.61)	103 (4.06)	21.5 (.85)	17.1 (.67)	36.6 (1.44)	106 (4.17)	26.1 (1.03)	13 (.51)	163.5 (6.44)	127.4 (5.02)	36.1 (1.42)
S-BSG-06	98 (3.86)	70 (2.76)	14 (.55)	35 (1.38)	66.7 (2.63)	58.8 (2.31)	33.7 (1.33)	17.5 (.69)	26 (1.02)	218.3 (8.59)	200 (7.87)	153 (6.02)	117 (4.61)	103 (4.06)	26 (1.02)	31.9 (1.26)	51.4 (2.02)	122 (4.80)	19.3 (.76)	13 (.51)	163.5 (6.44)	142.2 (5.60)	21.3 (.84)
S-BSG-10	120 (4.72)	82.6 (3.25)	18.7 (.74)	41.3 (1.63)	88.9 (3.50)	46.1 (1.81)	44.9 (1.77)	21.5 (.85)	32 (1.26)	253.3 (9.97)	235 (9.25)	188 (7.40)	149 (5.87)	135 (5.31)	34 (1.34)	43.2 (1.70)	62.7 (2.47)	155 (6.10)	21.1 (.83)	18 (.71)	180 (7.09)	—	—

Item / Model Numbers	AC Solenoid		DC/R Solenoid	
	L	j	L	j
S-BSG-03	68.8 (2.71)	158.7 (6.25)	78.1 (3.07)	168 (6.61)
S-BSG-06	54 (2.13)	158.7 (6.25)	63.3 (2.49)	168 (6.61)
S-BSG-10	41.8 (1.65)	—	51.1 (2.01)	—

DIMENSIONS IN MILLIMETRES (INCHES)

★ For the port screws, see the Plug-in Connector type on page 34.

Note: For dimensions of the valve mounting surface, see the installation drawing (P.13) of the sub-plate used together.



■ Plug-in Connector Type

S-BSG-03-06-*-*-*N-L-52/5280/5290

S-BSG-10-*-*-*N-52/5280/5290

Three positions of cable departure are available by loosening "Lock Nut" as shown. After location, tighten "Lock Nut" with torque in the range 10.3 to 11.3 Nm (91-100 IN. lbs.).

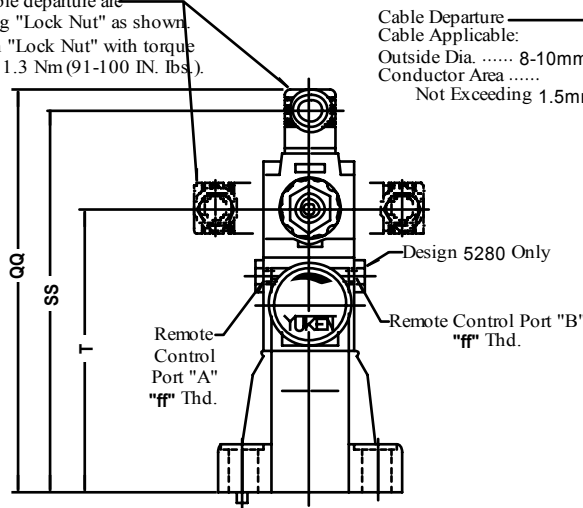

Cable Departure Cable Applicable:
 Outside Dia. 8-10mm(.31-.39 in.)
 Conductor Area
 Not Exceeding 1.5mm²(.002 SQ. in.)

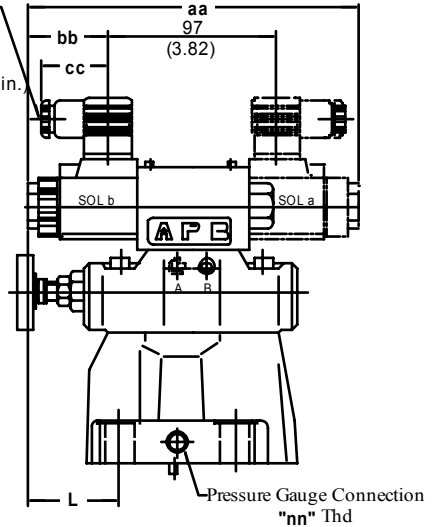

DIMENSIONS IN MILLIMETRES (INCHES)

Model Numbers	Dimensions mm (Inches)							Remarks
	L	T	SS	QQ	aa	bb	cc	
S-BSG-03-*-*-*A*-N	68.8 (2.71)	153 (6.02)	206 (8.11)	218 (8.58)	191.4 (7.54)	47.2 (1.86)	39 (1.54)	With AC Solenoid
S-BSG-06-*-*-*A*-N	54 (2.13)	153 (6.02)	206 (8.11)	218 (8.58)				
S-BSG-10-*-*-*A*-N	41.8 (1.65)	188 (7.40)	241 (9.49)	253 (9.96)				
S-BSG-03-*-*-*D*-N	78.1 (3.07)	153 (6.02)	217 (8.54)	229 (9.02)	210 (8.27)	56.5 (2.22)	39 (1.54)	With DC Solenoid
S-BSG-06-*-*-*D*-N	63.3 (2.49)	153 (6.02)	217 (8.54)	229 (9.02)				
S-BSG-10-*-*-*D*-N	51.1 (2.01)	188 (7.40)	252 (9.92)	264 (10.39)				
S-BSG-03-*-*-*R*-N	78.1 (3.07)	153 (6.02)	210.2 (8.28)	232 (9.13)	210 (8.27)	56.5 (2.22)	53 (2.09)	With AC → DC Solenoid
S-BSG-06-*-*-*R*-N	63.3 (2.49)	153 (6.02)	210.2 (8.28)	232 (9.13)				
S-BSG-10-*-*-*R*-N	51.1 (2.01)	188 (7.40)	245.2 (9.65)	267 (10.51)				

Model Numbers	Thread Size					
	Japanese Standard "JIS" Design 52		European Design Standard Design 5280		N. American Design Standard Design 5290	
	"ff" Thd.	"nn" Thd.	"ff" Thd.	"nn" Thd.	"ff" Thd.	"nn" Thd.
S-BSG-03-*-*-*N	Rc 1/8	Rc 1/4	1/8 BSP.F	1/4 BSP.F	1/8 NPT	1/4 NPT
S-BSG-06-*-*-*N						
S-BSG-10-*-*-*N						

Options-Models with Vent Restrictor

Terminal Box Type

A-S-BSG-03-**-**-L-52/5290

A-S-BSG-10-**-**-52/5290

Plug-in Connector Type

A-S-BSG-03-**-**-N-L-52/5280/5290

A-S-BSG-10-**-**-N-52/5280/5290

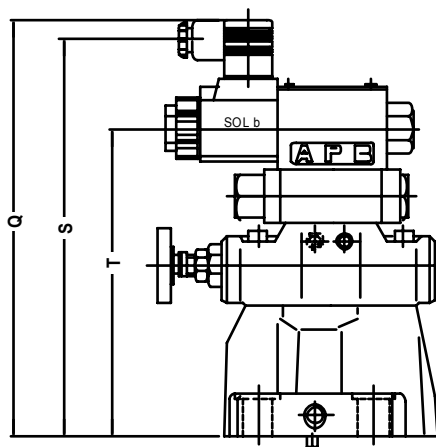
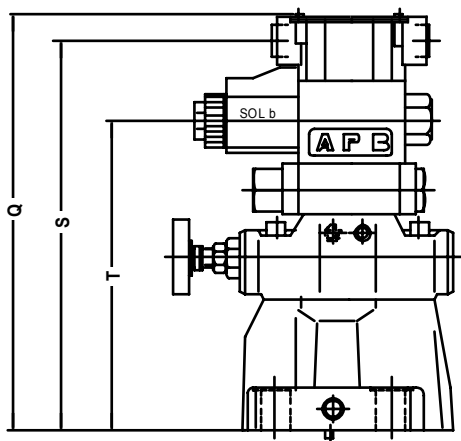

Model Numbers	Dimensions mm (Inches)			Remarks
	Q	S	T	
A-S-BSG-03-**-**-A*/D*/R	248.3 (9.78)	230(9.06)	183(7.20)	Terminal Box Type
A-S-BSG-06-**-**-A*/D*/R	248.3(9.78)	230(9.06)	183(7.20)	
A-S-BSG-10-**-**-A*/D*/R*	283.3(11.15)	235(9.25)	188(7.40)	
A-S-BSG-03-**-**-A*-N-L	248(9.76)	236(9.29)	183(7.20)	Plug-in Connector Type
A-S-BSG-03-**-**-D*-N-L	259(10.20)	247(9.72)		
A-S-BSG-03-**-**-R*-N-L	262(10.31)	240.2(9.46)		
A-S-BSG-06-**-**-A*-N-L	248(9.76)	236(9.29)	183(7.20)	
A-S-BSG-06-**-**-D*-N-L	259(10.20)	247(9.72)		
A-S-BSG-06-**-**-R*-N-L	262(10.31)	240.2(9.46)		
A-S-BSG-10-**-**-A*-N	283(11.14)	271(10.67)	188(7.40)	
A-S-BSG-10-**-**-D*-N	294(11.57)	282(11.10)		
A-S-BSG-10-**-**-R*-N	297(11.69)	275.2(10.83)		

Lead Wire Connection

Lead Wire Connection is the same way as the conventional type solenoid controlled relief valves. See page 27.



● Terminal Box Type

S-BSG-03,06,10-*-*-*/52/5290

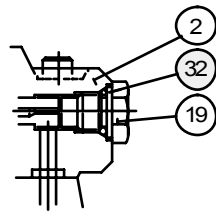
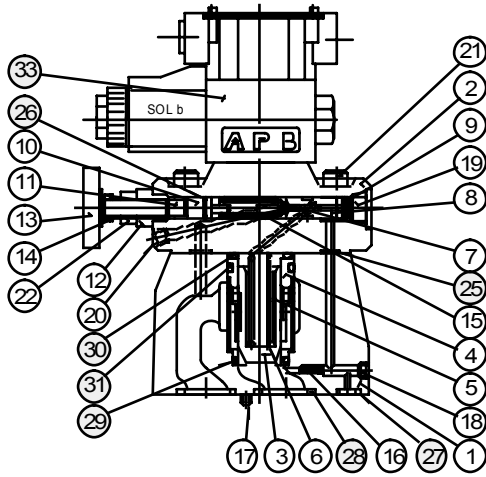

*-S-BSG-10

● Plug-in Connector Type

S-BSG-03,06,10-*-*-*/N-52/5280/5290

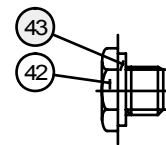
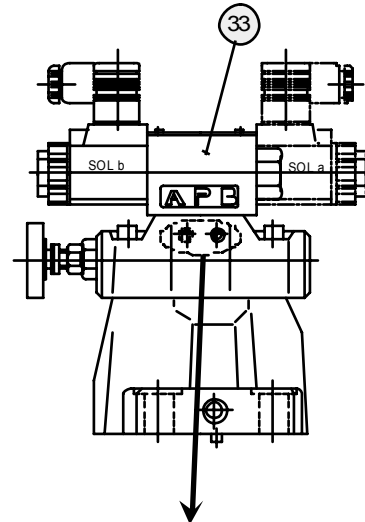

Design 5280 Only

● List of Seals

Item	Name of Parts	Part Numbers			Qty.
		S-BSG-03	S-BSG-06	S-BSG-10	
25	O-Ring	SO-NB-P9	SO-NB-P9	SO-NB-P9	2
26	O-Ring	SO-NA-P9	SO-NA-P9	SO-NA-P9	1
27	O-Ring	SO-NB-P9	SO-NB-P11	SO-NB-P9	1
28	O-Ring	SO-NB-P18	SO-NB-P28	SO-NB-P32	2
29	O-Ring	SO-NB-A024	SO-NB-A024	SO-NB-A128	1
30	O-Ring	SO-NB-P28	SO-NB-P28	SO-NB-P36	1
31	O-Ring	SO-NB-P32	SO-NB-P32	SO-NB-P42	1
32	O-Ring	—	—	SO-NB-P14	1
38 ^A	O-Ring	SO-NB-P8			2
40 ^A	O-Ring	SO-NB-P14			2
43	Bonded Seal	SG-FB-1/8	SG-FB-1/8	SG-FB-1/8	2

★ The O-Rings for item 38, 40 are used only for the models with the vent restrictor.

Note: When ordering the seals, please specify the seal kit number from the table right. In addition to the above seals, seals for the pilot valves are included in the seal kit.

For the detail of the pilot valve seals, see the catalogue No. Pub. EC-0402.

CAUTION

When making replacement of seals or solenoid assemblies, please do it carefully after reading through the relevant instructions in the Operator's Manual.

■ Option-Models with Vent Restrictor

A-S-BSG-03,06,10-*-*-*/52/5290
N-52/5280/5290

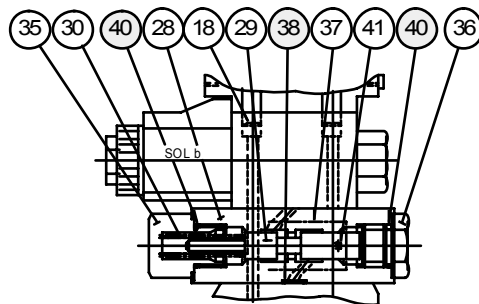

● List of Seal Kits

Model Numbers	Seal Kit Numbers
S-BSG-03	KS-S-BSG-03-51
S-BSG-06	KS-S-BSG-06-51
S-BSG-10	KS-S-BSG-10-51
A-S-BSG-03	KS-A-S-BSG-03-51
A-S-BSG-06	KS-A-S-BSG-06-51
A-S-BSG-10	KS-A-S-BSG-10-51

Note: No bonded seals are included in the seal kits.

● Pilot Valves

See page 37 for the pilot valve model numbers to be used.



● **List of Pilot Valves**

Type of Electrical Conduit Connection	Valve Model Numbers	Pilot Valve Model Numbers	Remarks
Terminal Box Type	*-S-BSG-03/06/10-* -2B3A-★ -52	DSG-01-2B3A-★-60	Japanese Standard "JIS"
	-S-BSG-03/06/10- -2B3B-★ -52	DSG-01-2B3B-★-60	
	-S-BSG-03/06/10- -2B2B-★ -52	DSG-01-2B2B-★-60	
	-S-BSG-03/06/10- -2B2-★ -52	DSG-01-2B2-★-60	
	-S-BSG-03/06/10- -3C2-★ -52	DSG-01-3C2-★-60	
	-S-BSG-03/06/10- -3C3-★ -52	DSG-01-3C3-★-60	
	-S-BSG-03/06/10- -2B3A-★ -5290	DSG-01-2B3A-★-6090	N. American Design Std.
	-S-BSG-03/06/10- -2B3B-★ -5290	DSG-01-2B3B-★-6090	
	-S-BSG-03/06/10- -2B2B-★ -5290	DSG-01-2B2B-★-6090	
	-S-BSG-03/06/10- -2B2-★ -5290	DSG-01-2B2-★-6090	
-S-BSG-03/06/10- -3C2-★ -5290	DSG-01-3C2-★-6090		
-S-BSG-03/06/10- -3C3-★ -5290	DSG-01-3C3-★-6090		
Plug-in Connector Type	*-S-BSG-03/06/10-* -2B3A-★ -N-52	DSG-01-2B3A-★-N-60	Japanese Standard "JIS"
	-S-BSG-03/06/10- -2B3B-★ -N-52	DSG-01-2B3B-★-N-60	
	-S-BSG-03/06/10- -2B2B-★ -N-52	DSG-01-2B2B-★-N-60	
	-S-BSG-03/06/10- -2B2-★ -N-52	DSG-01-2B2-★-N-60	
	-S-BSG-03/06/10- -3C2-★ -N-52	DSG-01-3C2-★-N-60	
	-S-BSG-03/06/10- -3C3-★ -N-52	DSG-01-3C3-★-N-60	
	-S-BSG-03/06/10- -2B3A-★ -N-5280	DSG-01-2B3A-★-N-60	European Design Std.
	-S-BSG-03/06/10- -2B3B-★ -N-5280	DSG-01-2B3B-★-N-60	
	-S-BSG-03/06/10- -2B2B-★ -N-5280	DSG-01-2B2B-★-N-60	
	-S-BSG-03/06/10- -2B2-★ -N-5280	DSG-01-2B2-★-N-60	
	-S-BSG-03/06/10- -3C2-★ -N-5280	DSG-01-3C2-★-N-60	
	-S-BSG-03/06/10- -3C3-★ -N-5280	DSG-01-3C3-★-N-60	
	-S-BSG-03/06/10- -2B3A-★ -N-5290	DSG-01-2B3A-★-N-6090	N. American Design Std.
	-S-BSG-03/06/10- -2B3B-★ -N-5290	DSG-01-2B3B-★-N-6090	
	-S-BSG-03/06/10- -2B2B-★ -N-5290	DSG-01-2B2B-★-N-6090	
	-S-BSG-03/06/10- -2B2-★ -N-5290	DSG-01-2B2-★-N-6090	
-S-BSG-03/06/10- -3C2-★ -N-5290	DSG-01-3C2-★-N-6090		
-S-BSG-03/06/10- -3C3-★ -N-5290	DSG-01-3C3-★-N-6090		

Note: 1. Fill a coil type (a symbol representing current/voltage) in section marked ★ .
 2. For the details of the pilot valves, see the Catalogue No. Pub. EC-0402.

Interchangeability in Installation between Old and New Design

Interchangeability with old products

Design 52 valve is one on which DSG-01, design 60 is mounted as a pilot valve. It is interchangeable with old design (S-BSG-*, design 51) in terms of specifications and mounting dimensions.

Interchangeability between conventional and low-noise type

Design 52 of the low-noise type is interchangeable for installation with design 47 of conventional types BSG-03/-06/-10. However, exterior shapes such as the position of the pressure adjustment handle are different.

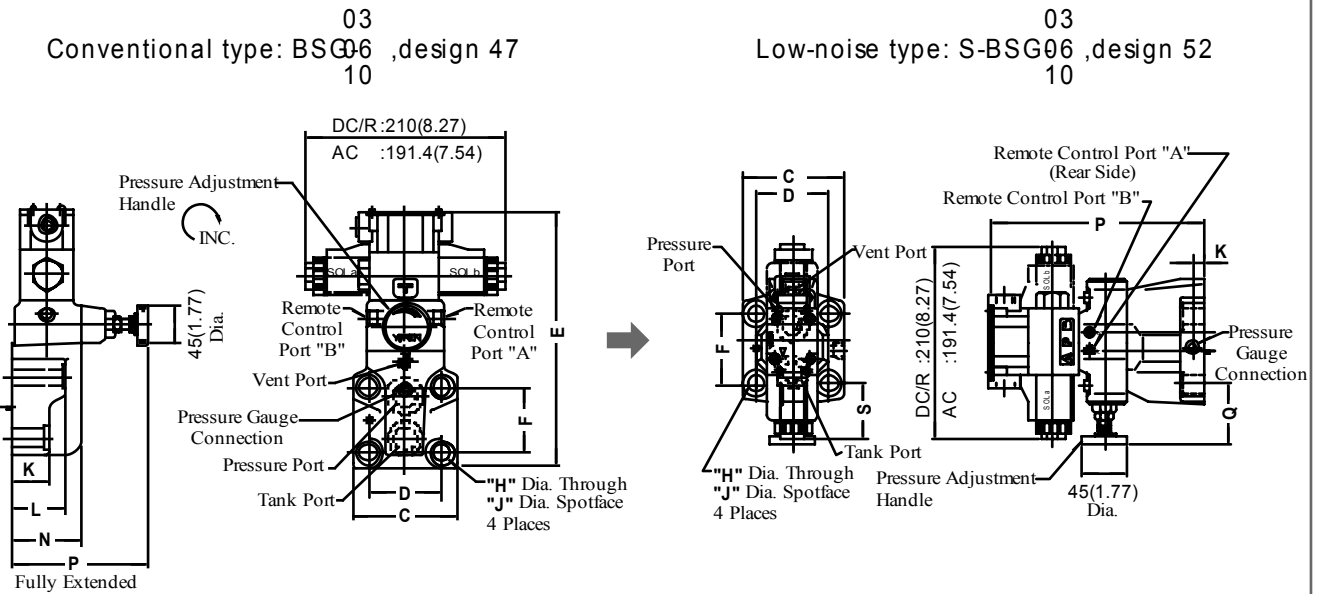

Model Numbers	Dimensions mm (Inches)									
	C	D	E	F	H	J	K	L	N	P
BSG-03	82 (3.23)	53.8 (2.12)	227.3 (8.95)	53.8 (2.12)	13.5 (.53)	21 (.83)	57 (2.24)	78 (3.07)	78 (3.07)	145 (5.71)
BSG-06	104 (4.09)	70 (2.76)	251.3 (9.89)	66.7 (2.63)	17.5 (.69)	26 (1.02)	40 (1.57)	60 (2.36)	78 (3.07)	145 (5.71)
BSG-10	124 (4.88)	82.6 (3.25)	285.3 (11.1)	88.9 (3.50)	21.5 (.85)	32 (1.26)	47 (1.85)	67 (2.64)	84 (3.31)	146 (5.75)

Model Numbers	Dimensions mm (Inches)									
	C	D	F	H	J	K	P	Q	S	
									AC	DC/R
S-BSG-03	76 (2.99)	53.8 (2.12)	53.8 (2.12)	13.5 (.53)	21 (.83)	13 (.51)	218.3 (8.59)	73.6 (2.90)	68.8 (2.71)	78.1 (3.07)
S-BSG-06	98 (3.86)	70 (2.76)	66.7 (2.63)	17.5 (.69)	26 (1.02)	13 (.51)	218.3 (8.59)	58.8 (2.31)	54 (2.13)	63.3 (2.49)
S-BSG-10	120 (4.72)	82.6 (3.25)	88.9 (3.50)	21.5 (.85)	32 (1.26)	18 (.71)	253.3 (9.97)	46.1 (1.81)	41.8 (1.65)	51.1 (2.01)