



DECELERATION VALVES
ZT / ZG-03 / 06 / 10 (3/8, 3/4, 1-1/4)
DECELERATION AND CHECK VALVES
ZCT / ZCG-03 / 06 / 10 (3/8, 3/4, 1-1/4)
Threaded Connections / Sub-plate

FLOW CONTROLS

Specifications / Model Number Designation

Up to 21 MPa (3050 PSI), 200 L/min (52.8 U.S.GPM)

These valves are available either with or without an integral check valve which allows free reverse flow. Flow rate through the valve is regulated by the movement of the spool, which is operated by a cam. When the spool is depressed, the flow is decreased in Normally Open type valves and increased in Normally Closed type valves. Their principal use is to control the speed of actuators in machine tools and similar applications.

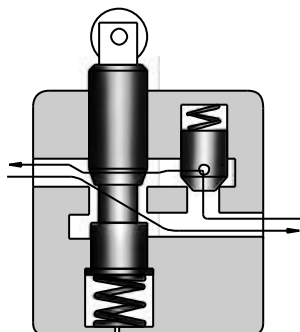

Normally Open Type

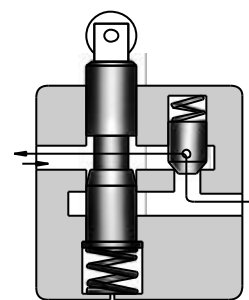

Normally Closed Type

Specifications

Model Numbers		Max. Flow L/min (U.S.GPM)	Max. Operating Pressure MPa (PSI)	Approx. Mass kg (lbs.)	
Threaded Connection	Sub-plate Mounting			Z*T	Z*G
ZT/ZCT-03-*-22/2280/ 2290	ZG/ZCG-03-*-22/2290	30 (7.9)	21 (3050)	4.3 (9.5)	4.3 (9.5)
	ZG/ZCG-06-*-22/2290	80 (21.1)		8.7 (19.2)	8.7 (19.2)
ZT/ZCT-06-*-22/2280/	ZG/ZCG-10-*-22/2290	200 (52.8)		17 (37.5)	17 (37.5)

Model Number Designation

F-	ZC	T	-03	-T	-C	-22	*
Special Seals	Series Number	Type of Mounting	Valve Size	With Adjustable Needle Valve for By-Pass Line	Spool Type	Design Number	Design Standards
F: Special Seals for Phosphate Ester Type Fluids (Omit if not required)	Z: Deceleration Valve	T: Threaded Connection	03	T: With Adjustable Needle Valve (Omit if not required)	None: Normally Open Type C: Normally Closed Type	22	None:Japanese Std. "JIS" 80:European Design Std. 90:N. American Design Std.
			06			22	
			10			22	
		G: Sub-plate Mounting	03			22	None:Japanese Std. "JIS" & European Design Std. 90:N. American Design Std.
			06			22	
			10			22	
	ZC: Deceleration and Check Valve	T: Threaded Connection	03	T: With Adjustable Needle Valve (Omit if not required)	None: Normally Open Type C: Normally Closed Type	22	None:Japanese Std. "JIS" 80:European Design Std. 90:N. American Design Std.
			06			22	
			10			22	
		G: Sub-plate Mounting	03			22	None:Japanese Std. "JIS" & European Design Std. 90:N. American Design Std.
			06			22	
			10			22	

Graphic Symbols

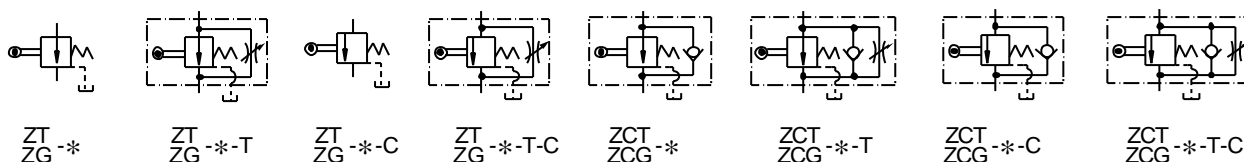

Hydraulic Fluids

Fluid Types

Any type of hydraulic fluids listed in the table below can be used.

Petroleum base oils	Use fluids equivalent to ISO VG 32 or VG 46.
Synthetic fluids	Use phosphate ester or polyol ester fluid. When phosphate ester fluid is used, prefix "F-" to the model number because the special seals (fluororubber) are required to be used.
Water containing fluids	Use water-glycol fluid.

Note: For use with hydraulic fluids other than those listed above, please consult your Yuken representatives in advance.

Recommended Viscosity and Oil Temperatures

Viscosity ranging between 15 - 400 mm²/s (77 to 1800 SSU).

Oil temperatures between -15/+70°C (5 - 158°F).

Use hydraulic fluids which satisfy the recommended viscosity and oil temperatures given above.

Control of Contamination

Due caution must be paid to maintaining control over contamination of the hydraulic fluids which may otherwise lead to breakdowns and shorten the life of the valves. Please maintain the degree of contamination within NAS 1638-Grade 12. Use 25 μm or finer line filter.

Instructions

Force to Depress Spool

Model Numbers	Force N (lbs.)
ZT/ZG - ZCT/ZCG03	150 (337)
ZT/ZG - ZCT/ZCG06	270 (607)
ZT/ZG - ZCT/ZCG10	400 (899)

Total Leakage at Spool Fully Closed

[Viscosity: 20 mm²/s (98 SSU)]

Model Numbers	Total Leakage cm ³ /min (cu.in./min)				
	Pressure MPa (PSI)				
	1 (145)	2 (290)	5 (730)	10 (1450)	21 (3050)
ZT/ZG - ZCT/ZCG03	9 (.55)	18 (1.10)	44 (2.7)	88 (5.4)	185 (11.3)
ZT/ZG - ZCT/ZCG06	9 (.55)	17 (1.04)	43 (2.6)	86 (5.2)	180 (11.0)
ZT/ZG - ZCT/ZCG10	10 (.61)	20 (1.22)	49 (3.0)	98 (6.0)	205 (12.5)

Drain Port Back Pressure

Limit the drain port back pressure to 0.1 MPa (15 PSI).

In addition, connect the drain pipe independently and directly to the tank.

Attachment

Mounting Bolts

Valve Model Numbers	Socket Head Cap Screw		Qty.
	Japanese Std. "JIS" and European Design Std.	N. American Design Std.	
ZG/ZCG-03	M8 × 75 Lg.	5/16-18 UNC × 3 Lg.	4
ZG/ZCG-06	M10 × 100	3/8-16 UNC × 4 Lg.	4
ZG/ZCG-10	Lg.	1/2-13 UNC × 4-3/4 Lg.	4

Option

Bypass throttle valves

To allow a metered flow between ports even when the flow is stopped by the spool.

Sub-plate

Valve Model Numbers	Japanese Standard "JIS"		European Design Standard		N.American Design Standard		Approx. Mass kg (lbs.)
	Sub-plate Model No.	Thread Size	Sub-plate Model No.	Thread Size	Sub-plate Model No.	Thread Size	
ZG/ZCG-03	ZGM-03-21	Rc 3/8	ZGM-03-2180	3/8 BSP.F	ZGM-03-2190	3/8 NPT	2 (4.4)
ZG/ZCG-06	ZGM-06-21	Rc 3/4	ZGM-06-2180	3/4 BSP.F	ZGM-06-2190	3/4 NPT	3.8 (8.4)
ZG/ZCG-10	ZGM-10-21	Rc 1-1/4	ZGM-10-2180	1-1/4 BSP.F	ZGM-10-2190	1-1/4 NPT	9 (19.8)

- Sub-plates are available. Specify the sub-plate model number from the table above. When sub-plates are not used, the mounting surface should have a good machined finish.

ZT/ZCT-03-*-* -22/2280/2290
 ZT/ZCT-06-*-* -22/2280/2290
 ZT/ZCT-10-*-* -22/2280/2290

**DIMENSIONS IN
MILLIMETRES (INCHES)**

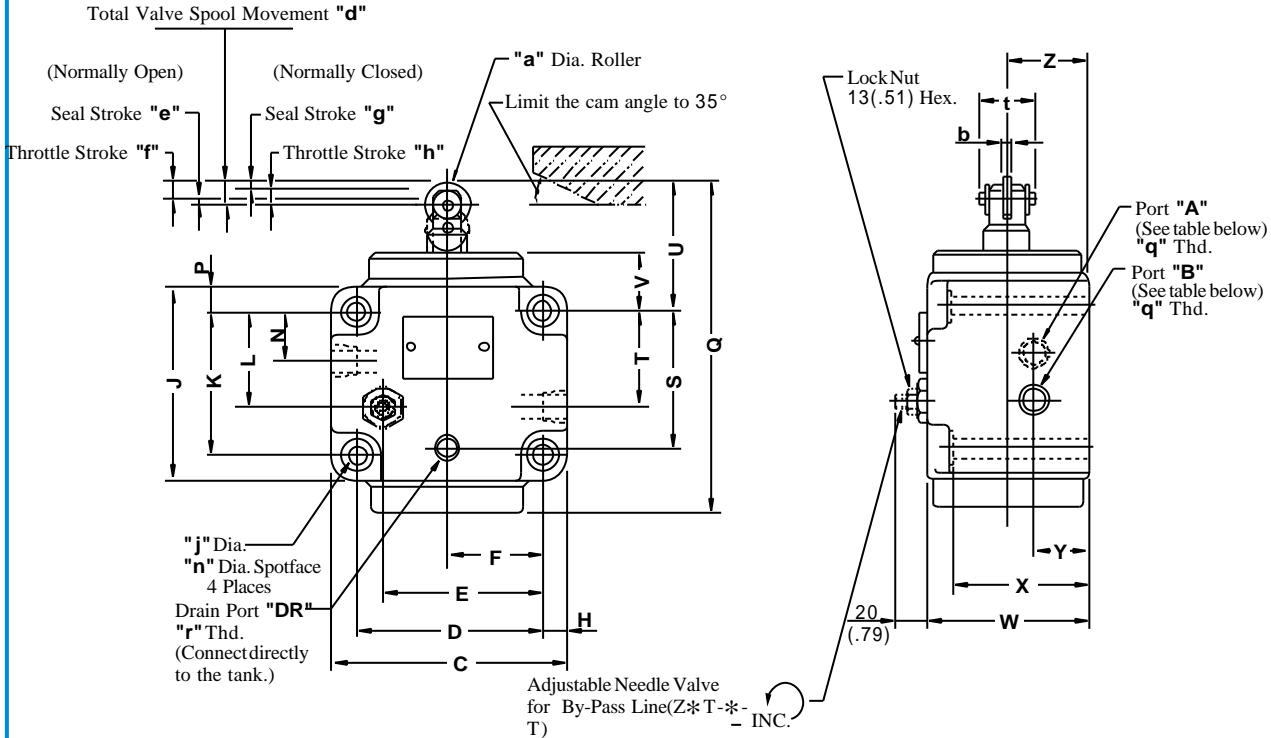

Model Numbers	Port "A"	Port "B"
ZT-*	Controlled flow inlet	Controlled flow outlet
ZCT-*	Controlled flow inlet or Reversed free flow outlet	Controlled flow outlet or Reversed free flow inlet

Model Numbers	"q" Thd.	"r" Thd.
ZT/ZCT-03-*-* -22	Rc 3/8	Rc 1/4
ZT/ZCT-03-*-* -2280	3/8 BSP.F	1/4 BSP.F
ZT/ZCT-03-*-* -2290	3/8 NPT	1/4 NPT
ZT/ZCT-06-*-* -22	Rc 3/4	Rc 1/4
ZT/ZCT-06-*-* -2280	3/4 BSP.F	1/4 BSP.F
ZT/ZCT-06-*-* -2290	3/4 NPT	1/4 NPT
ZT/ZCT-10-*-* -22	Rc 1-1/4	Rc 1/4
ZT/ZCT-10-*-* -2280	1-1/4 BSP.F	1/4 BSP.F
ZT/ZCT-10-*-* -2290	1-1/4 NPT	1/4 NPT

Model Numbers	Dimensions mm (Inches)															
	C	D	E	F	H	J	K	L	N	P	Q	S	T	U	V	W
ZT/ZCT-03	102 (4.02)	80 (3.15)	66 (2.60)	40 (1.57)	11 (.43)	82 (3.23)	60 (2.36)	41 (1.61)	20 (.79)	11 (.43)	141 (5.55)	58 (2.28)	40 (1.57)	56 (2.20)	25 (.98)	70 (2.76)
ZT/ZCT-06	120 (4.72)	98 (3.86)	82 (3.23)	49 (1.93)	11 (.43)	106 (4.17)	84 (3.31)	57 (2.24)	32 (1.26)	11 (.43)	176 (6.93)	81 (3.19)	57 (2.24)	65 (2.56)	27 (1.06)	95 (3.74)
ZT/ZCT-10	160 (6.30)	132 (5.20)	103 (4.06)	66 (2.60)	14 (.55)	140 (5.51)	112 (4.41)	75 (2.95)	40 (1.57)	14 (.55)	224 (8.82)	106 (4.17)	75 (2.95)	80 (3.15)	32 (1.26)	110 (4.33)

Model Numbers	Dimensions mm (Inches)												
	X	Y	Z	a	b	d	e	f	g	h	j	n	t
ZT/ZCT-03	60 (2.36)	25 (.98)	35 (1.38)	18 (.71)	6 (.24)	10 (.39)	2 (.08)	8 (.31)	2 (.08)	8 (.31)	8.8 (.35)	14 (.55)	24.5 (.96)
ZT/ZCT-06	85 (3.35)	32 (1.26)	50 (1.97)	22 (.87)	8 (.31)	13 (.51)	3 (.12)	10 (.39)	3 (.12)	10 (.39)	11 (.43)	17.5 (.69)	29 (1.14)
ZT/ZCT-10	96 (3.78)	40 (1.57)	55 (2.17)	28 (1.10)	10 (.39)	18 (.71)	3 (.12)	15 (.59)	3 (.12)	15 (.59)	13.5 (.53)	21 (.83)	34 (1.34)



ZG/ZCG-03-*-* -22/2290
 ZG/ZCG-06-*-* -22/2290
 ZG/ZCG-10-*-* -22/2290

DIMENSIONS IN
MILLIMETRES (INCHES)

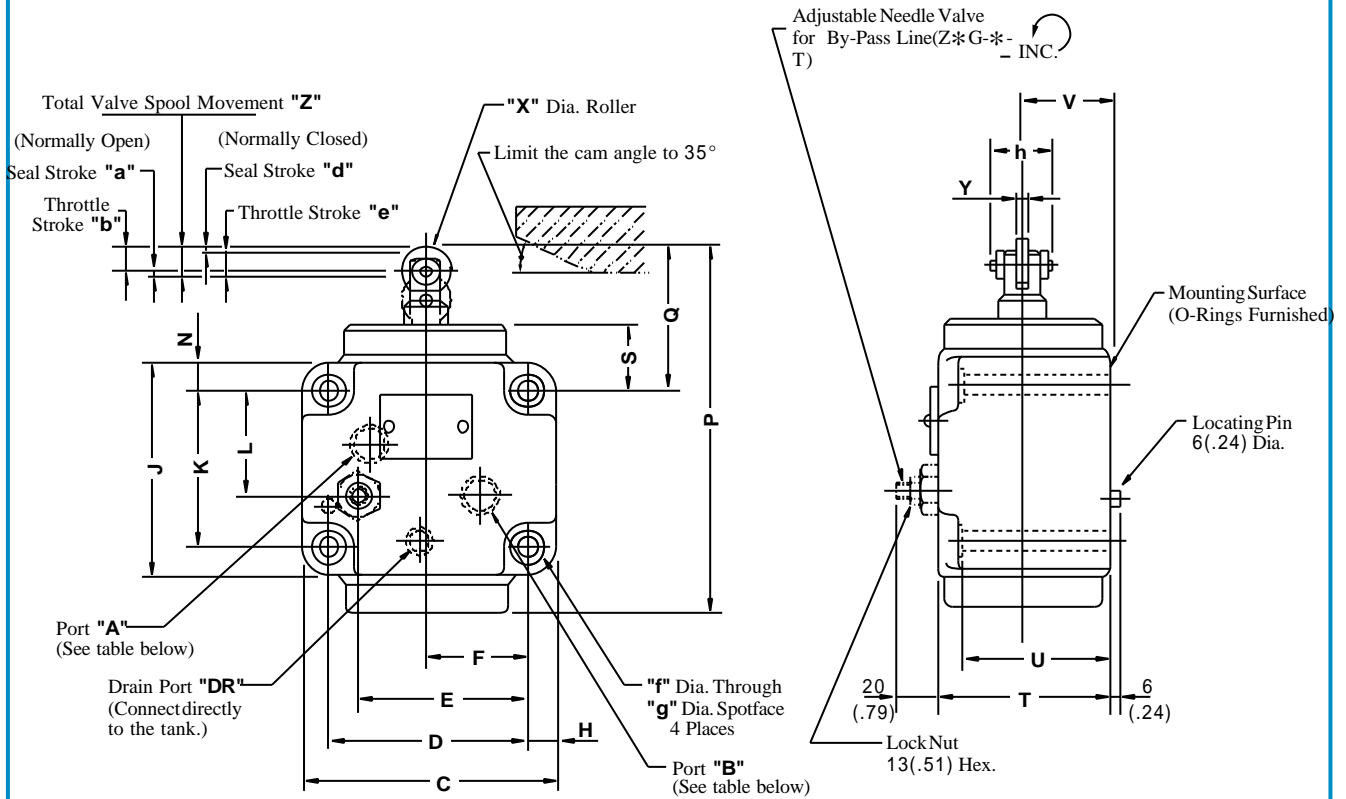

Model Numbers	Port "A"	Port "B"
ZG-*	Controlled flow inlet	Controlled flow outlet
ZCG-*	Controlled flow inlet or Reversed free flow outlet	Controlled flow outlet or Reversed free flow inlet

Model Numbers	Dimensions mm (Inches)												
	C	D	E	F	H	J	K	L	N	P	Q	S	T
ZG/ZCG-03	102 (4.02)	80 (3.15)	66 (2.60)	40 (1.57)	11 (.43)	82 (3.23)	60 (2.36)	41 (1.61)	11 (.43)	141 (5.55)	56 (2.20)	25 (.98)	70 (2.76)
ZG/ZCG-06	120 (4.72)	98 (3.86)	82 (3.23)	49 (1.93)	11 (.43)	106 (4.17)	84 (3.31)	57 (2.24)	11 (.43)	176 (6.93)	65 (2.56)	27 (1.06)	95 (3.74)
ZG/ZCG-10	160 (6.30)	132 (5.20)	103 (4.06)	66 (2.60)	14 (.55)	140 (5.51)	112 (4.41)	75 (2.95)	14 (.55)	224 (8.82)	80 (3.15)	32 (1.26)	110 (4.33)

Model Numbers	Dimensions mm (Inches)											
	U	V	X	Y	Z	a	b	d	e	f	g	h
ZG/ZCG-03	60 (2.36)	35 (1.38)	18 (.71)	6 (.24)	10 (.39)	2 (.08)	8 (.31)	2 (.08)	8 (.31)	8.8 (.35)	14 (.55)	24.5 (.96)
ZG/ZCG-06	85 (3.35)	50 (1.97)	22 (.87)	8 (.31)	13 (.51)	3 (.12)	10 (.39)	3 (.12)	10 (.39)	11 (.43)	17.5 (.69)	29 (1.14)
ZG/ZCG-10	96 (3.78)	55 (2.17)	28 (1.10)	10 (.39)	18 (.71)	3 (.12)	15 (.59)	3 (.12)	15 (.59)	13.5 (.53)	21 (.83)	34 (1.34)

ZGM-03-21/2180/2190
 ZGM-06-21/2180/2190
 ZGM-10-21/2180/2190

DIMENSIONS IN
 MILLIMETRES (INCHES)

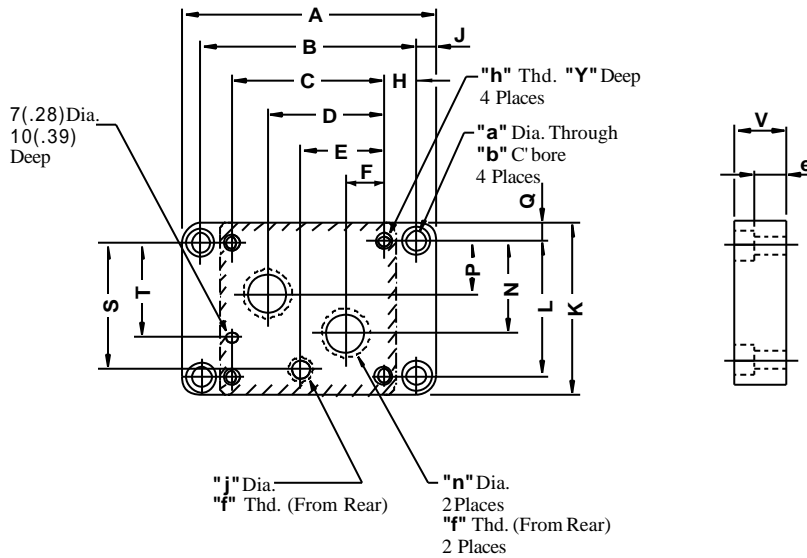

Model Numbers	Thd. Size			mm (Inches)	
	"f" Thd.	"g" Thd.	"h" Thd.	j	n
ZGM-03-21	Rc 3/8	Rc 1/4	M8	6.2 (.24)	14 (.55)
ZGM-03-2180	3/8 BSP.F	1/4 BSP.F			15 (.59)
ZGM-03-2190	3/8 NPT	1/4 NPT			14 (.55)
ZGM-06-21	Rc 3/4	Rc 1/4	M10	6.2 (.24)	23 (.91)
ZGM-06-2180	3/4 BSP.F	1/4 BSP.F			24.5 (.96)
ZGM-06-2190	3/4 NPT	1/4 NPT			23 (.91)
ZGM-10-21	Rc 1-1/4	Rc 1/4	M12	11 (.43)	29 (1.14)
ZGM-10-2180	1-1/4 BSP.F	1/4 BSP.F			
ZGM-10-2190	1-1/4 NPT	1/4 NPT			

Model Numbers	Dimensions mm (Inches)													
	A	B	C	D	E	F	H	J	K	L	N	P	Q	S
ZGM-03	146 (5.75)	124 (4.88)	80 (3.15)	60 (2.36)	42 (1.65)	20 (.79)	22 (.87)	11 (.43)	85 (3.35)	60 (2.36)	40 (1.57)	20 (.79)	12.5 (.49)	58 (2.28)
ZGM-06	160 (6.30)	138 (5.43)	98 (3.86)	74 (2.91)	53 (2.09)	24 (.94)	20 (.79)	11 (.43)	108 (4.25)	84 (3.31)	57 (2.24)	32 (1.26)	12 (.47)	81 (3.19)
ZGM-10	218 (8.58)	190 (7.48)	132 (5.20)	98 (3.86)	70 (2.76)	34 (1.34)	29 (1.14)	14 (.55)	140 (5.51)	112 (4.41)	75 (2.95)	40 (1.57)	14 (.55)	106 (4.17)

Model Numbers	Dimensions mm (Inches)					
	T	V	Y	a	b	e
ZGM-03	44 (1.73)	26 (1.02)	18 (.71)	11 (.43)	17.5 (.69)	15.2 (0.60)
ZGM-06	60 (2.36)	35 (1.38)	18 (.71)	11 (.43)	17.5 (.69)	24.2 (0.95)
ZGM-10	87 (3.43)	45 (1.77)	25 (.98)	14 (.55)	21 (.83)	31.5 (1.24)

Performance Characteristics

Hydraulic Fluid: Viscosity 20 mm²/s (98 SSU) , Specific Gravity 0.850

■ Pressure Drop for Reversed Free Flow

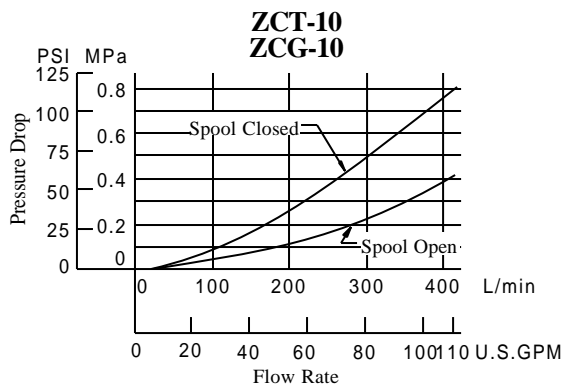
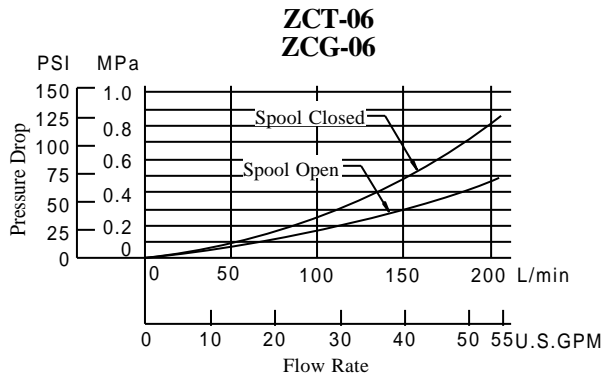
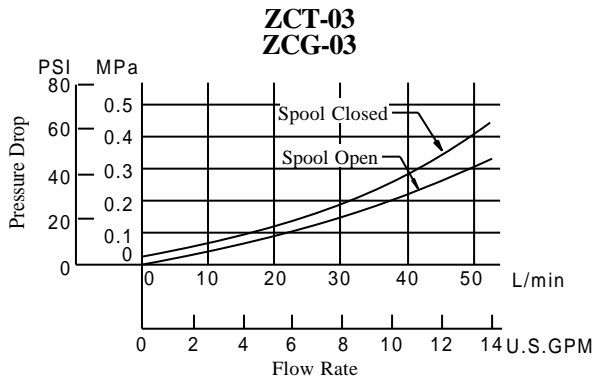

■ Metred Flow vs. Spool Depression

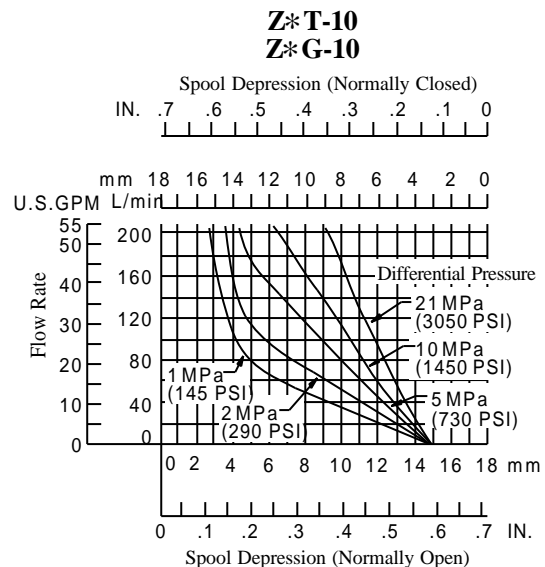
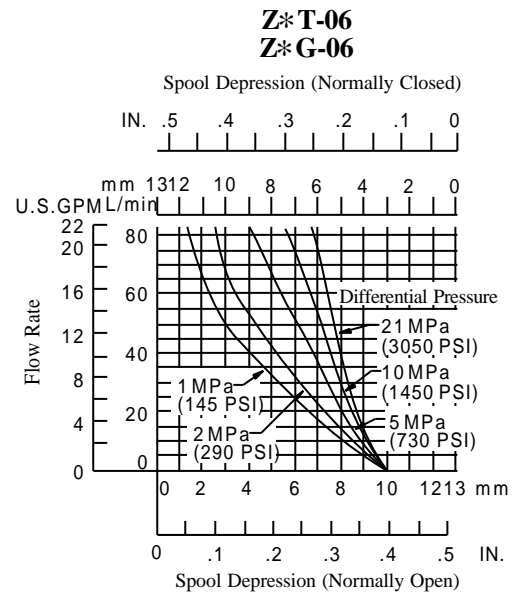
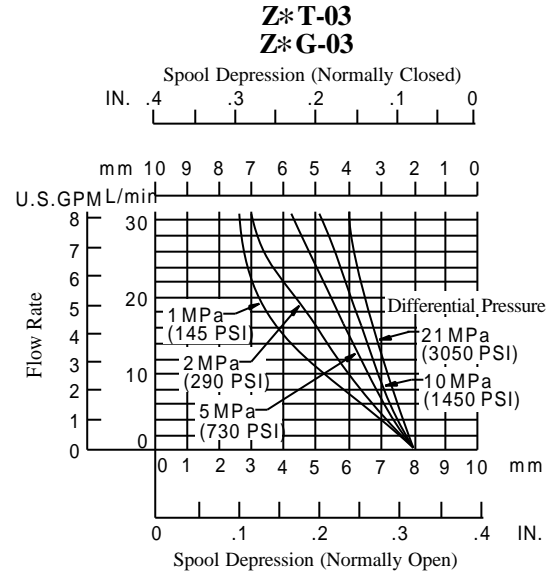

Hydraulic Fluid: Viscosity 20 mm²/s (98 SSU) , Specific Gravity 0.850

■ Metred Flow for Needle Valve

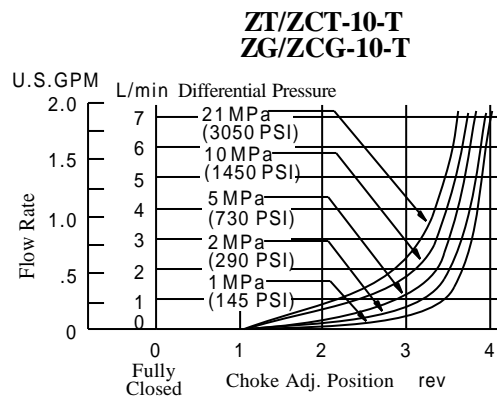
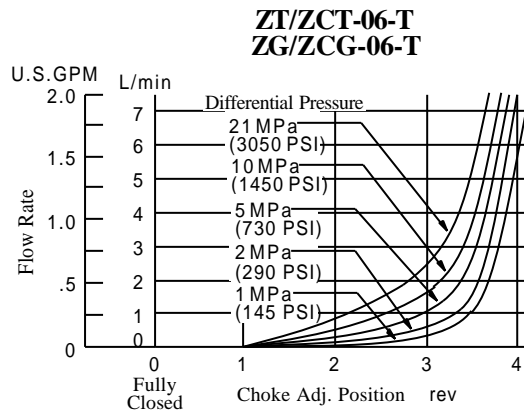
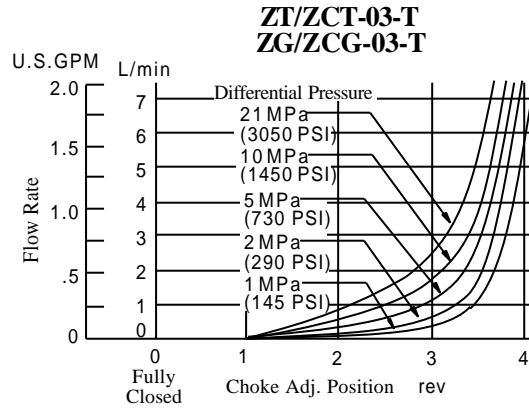

Spare Parts List

ZT/ZCT-03-*-* -22/2280/2290
 ZT/ZCT-06-*-* -22/2280/2290
 ZT/ZCT-10-*-* -22/2280/2290

CAUTION

When making replacement of seals, please do it carefully after reading through the relevant instructions in the Operator's Manual.

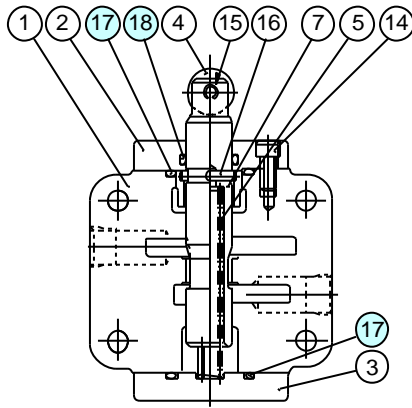

With Check Valve
(ZCT-*)

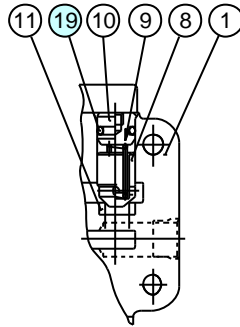

With Adjustable Needle Valve
for By-Pass Line

(ZT
ZCT-* -I)

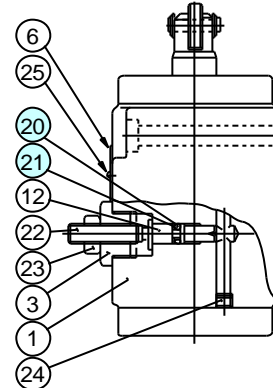

List of Seals

Item	Name of Parts	Part Numbers			Qty.
		ZT ZCT-03	ZT ZCT-06	ZT ZCT-10	
17	O-Ring	SO-NB-P32	SO-NB-P36	SO-NB-P49	2
18	O-Ring	SO-NA-P20	SO-NA-P25	SO-NA-P32	1
19	O-Ring	SO-NB-P12	SO-NB-P18	SO-NB-	1
20	O-Ring	SO-NA-P5	SO-NA-P5	P22A	1
21	Back Up Ring	SO-BB-P5	SO-BB-P5	SO-NA-P5	1

Note: When ordering the seals, please specify the seal kit number from the table right.

List of Seal Kits

Model Numbers	Seal Kit Numbers
ZT-03	KS-ZT-03-22
ZT-06	KS-ZT-06-22
ZT-10	KS-ZT-10-22
ZCT-	KS-ZCT-03-
03	22
ZCT-	KS-ZCT-06-

ZG/ZCG-03-*-* -22/2290

ZG/ZCG-06-*-* -22/2290

ZG/ZCG-10-*-* -22/2290

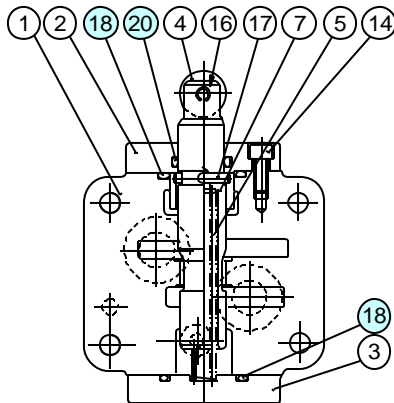

With Check Valve
(ZCG-*)

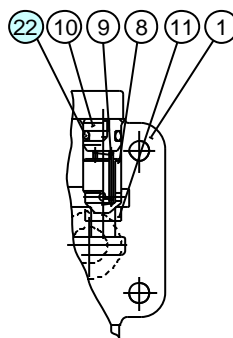

With Adjustable Needle Valve
for By-Pass Line

(ZG
ZCG-* -I)

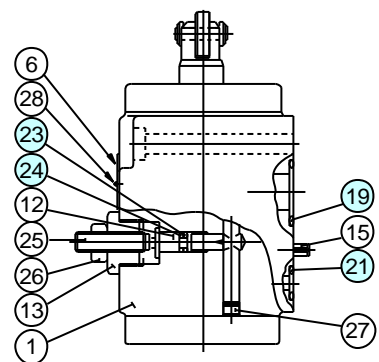

List of Seals

Item	Name of Parts	Part Numbers			Qty.
		ZG ZCG-03	ZG ZCG-06	ZG ZCG-10	
18	O-Ring	SO-NB-P32	SO-NB-P36	SO-NB-P49	2
19	O-Ring	SO-NB-P18	SO-NB-P28	SO-NB-P32	2
20	O-Ring	SO-NA-P20	SO-NA-P25	SO-NA-P32	1
21	O-Ring	SO-NB-P9	SO-NB-P14	SO-NB-P14	1
22	O-Ring	SO-NB-P12	SO-NB-P18	SO-NB-	1
23	O-Ring	SO-NA-P5	SO-NA-P5	P22A	1
24	Back Up Ring	SO-BB-P5	SO-BB-P5	SO-NA-P5	1

Note: When ordering the seals, please specify the seal kit number from the table right.

List of Seal Kits

Model Numbers	Seal Kit Numbers
ZG-03	KS-ZG-03-22
ZG-06	KS-ZG-06-22
ZG-10	KS-ZG-10-22
ZCG-	KS-ZCG-03-
03	22
ZCG-	KS-ZCG-06-